



Opinion Makers Section

Carlos Henggeler Antunes (1,2) and Carla Oliveira Henriques (2,3)

**(1) Dept. of Electrical Engineering and Computers,
University of Coimbra, Polo II, 3030-290 Coimbra,
Portugal**

**(2) INESC Coimbra, Rua Antero de Quental 199, 3000-
033 Coimbra, Portugal**

**(3) ISCAC, Quinta Agrícola, Bencanta, 3040-316
Coimbra, Portugal**

e-mails: ch@deec.uc.pt; coliv@inescc.pt

Multi-Objective Optimization and Multi-Criteria Decision Analysis in the Energy Sector (part II – MCDA)

Multi-criteria decision analysis approaches

MCDA methods become increasingly popular in energy decision-making due to their capability to deal with complex decision processes, in face of multiple and conflicting evaluation criteria (of technical, economic, environmental and social nature), different stakeholders with different views and preferences, several sources of uncertainty and distinct time frames. Literature reviews with specific focuses on the use of MCDA in energy problems have been reported. Hobbs and Meier (2000) provide a wide review of MCDM methods and energy-environment applications. Greening and Bernow (2004) describe a modeling framework incorporating developments in integrated assessment of energy and environmental issues, and suggest a strategy for developing a set of coordinated policies from varying levels of information about policy attributes and DM's preferences. Pohekar and Ramachandran (2004) review the application of various MCDM methods in the framework of sustainable energy planning. Løken (2007) provide an overview of some of the most relevant MCDA methods

proposed in the literature. Mirakyan and Guio (2013) present a review of methods and tools for integrated energy planning in cities and territories, concluding that the purpose of MCDA methodologies is not just required to define the "right" energy plan but rather to support the understanding of the multi-criteria complex situation that supports interactive planning and learning, helping people to systematically consider, articulate and apply value judgments.

The problems most often dealt with with MCDA approaches are:

- Comparison of power generation technologies, involving the appraisal of available primary energy sources and technological options, considering conventional technologies and/or renewable energy technologies.
- Formulation and development of energy plans and policies, involving the choices faced by energy planners at the national, regional or local level seeking to identify the most desired one among alternative scenarios, taking into account the public debate on energy policy, energy conservation strategies and energy resource allocation issues.
- Selection of energy projects, namely concerning renewable energy investments for electricity generation.
- Location decisions, namely focussing on the siting of new wind farms and hydro and thermal power plants, also complemented with choices regarding operational parameters.
- Energy efficiency studies, mainly devoted to the evaluation of energy efficiency measures and programs either in technology replacement or building refurbishment.

3.1. Criteria

The main criteria used in energy decision-making studies may be broadly categorized as reflecting technical, economic, environmental and social axes of evaluation.

Technical criteria include adaptability (the technology's potential to be adapted to actual conditions for energy production), availability (which is often used to indicate the amount of time a unit can be used for electricity and/or steam production, and is relevant for assessing intermittent renewable energy sources), continuity and predictability (reflecting the technology's ability to maintain stable the energy generated without being affected by external factors), diversity (namely concerning energy production mix, technology or supply sources), efficiency (ratio of energy output vs. input), feasibility (as a surrogate for confidence on implementation technologies or policies), local technical know-how (qualitative assessment of the complexity of the technology and the capacity of local actors to ensure an appropriate support for its installation and maintenance), maturity of the technology (the technology's maturity rate and its penetration in international markets, perceived as technological advantage), peak load response (technology's ability to respond promptly to large variations in demand), generation capacity, reliability (technology's capacity to perform as designed, resistance to failure, ability to perform a required function under stated conditions for a specified period of time, ability of failure without catastrophic consequences), risk (of a major disaster or safety of the implementation of a policy), security (of the supply system, reduction of energy dependence or fuel imports), technical spin-off (development of analogous technologies).

Economic criteria include cost and economic performance criteria. Cost criteria are modeled through externality costs (imposed on society and environment but not accounted for by the producers and consumers of energy, and therefore generally not included in market prices), fuel costs (provision of raw materials, e.g. coal or natural gas for conventional thermal plants or uranium for nuclear power plants, for the operation of the energy supply system, also including extraction or mining, transportation and possible fuel processing), infrastructure costs (investments in transmission network required by each scenario, in grid connections, etc.), investment cost (purchase of mechanical equipment, technological installations, construction of roads and connections to the national grid, engineering services, drilling and other incidental construction work), operation and maintenance costs (wages and the funds spent for energy, products and services, and preventive and corrective maintenance works), production costs (assessing how commercially competitive the system is compared with other production technologies).

Economic performance criteria include economic impacts (capacity of the energy project or policy of promoting local/regional/national economic development, or the impact on the dynamics of the national industry and local income, or even the impact on GDP or GNP), economic viability (evaluates the energy policy/project using typical indicators, such as net present value, internal rate of return,

cost-benefit analysis, payback period, useful life). Other economic criteria may consider political, fiscal, legal, and commercial criteria, e.g. availability of funds, compatibility with the national energy policy objectives, political acceptance, geopolitical issues, legal framework, commercial aspects, market size, energy price stability, duration of preparation and implementation phases for the evaluation of different energy policy implementations.

Environmental criteria may be broadly devoted to appraise local and global impacts. Local impacts include acidification and eutrophication, different types of emissions (CH₄, CO₂, NO_x, SO₂, SO_x, etc.), effects on natural environment, land use, local pollutants, noise, particulate matters, photochemical ozone creation, potential radioactivity, visual impact, and wastes. Global impacts account for climate change, namely using global warming potential and greenhouse gas emissions as surrogates, resource depletion, sustainability of energy resources.

Social criteria include health impacts (in general compared using the concept of expected years-of-life lost), risks (e.g., of fatal accidents or injuries, food safety), development (job creation, regional development, and social impacts), and acceptability (social or to the users) issues.

3.2. Methods

MCDA methods to tackle problems in the energy sector mainly include: value and utility theory approaches, outranking approaches, AHP/ANP approaches and other approaches. Simple Additive Weighting is mainly considered in power generation technology comparisons and in developing sustainability indices. MAUT is mostly used to capture the uncertainty relating to the outcomes of alternatives rather than the uncertainty relating to attribute values, namely in energy efficiency studies. MAVT is mainly used in power generation technology comparisons, in particular to rank power expansion alternatives or to prioritize investment portfolios in capacity expansion and energy security problems. The Simple Multi-Attribute Rated Technique (SMART) is mostly used for renewable energy planning. The Ordered Weighted Average (OWA), which combines non-weighted and weighted linguistic information, is used in the formulation of sustainable technological energy priorities, the assessment of renewable energy producers' operational environment, and to derive suitability indices to install power.

The outranking approaches (ELECTRE - elimination and choice translating reality - family of methods), are used in ranking of renewable energy resources and recommending future energy sources, assessment of agricultural biogas plants, definition of national priorities for GHG emissions, selection of wind energy projects, evaluation of energy-

efficiency initiatives, and the assessment of risk in natural gas pipelines. The several versions of PROMETHEE (preference ranking organization method for enrichment evaluation) are used in energy plans and policies concerning the design of renewable energy projects and policies, sustainable energy planning, comparison of power generation technologies, and ranking the performance of different biomass feedstock.

ANP is applied on power generation technology studies, in particular in the evaluation of alternative fuels for electricity generation and energy sources for a country. Several applications of AHP in combination with other methods have been reported, including the evaluation of conventional and renewable energy sources for space heating in the household sector, selection of renewable energy alternatives and energy policy options, environmental performance of urban energy use plans, and selection of energy policies and production sites, renewable energy projects, and optimal locations for thermal power plants.

TOPSIS (technique for order preference by similarity to ideal solution) applications are mostly focused on the evaluation and selection of energy generation processes and technologies as well as energy systems performance, including determining the best compromise alternative fuel mode for public transportation, selection of the best energy technology alternative, ranking the alternative locations of thermal power plants, selection of the most sustainable electricity production technologies.

NAIADE (novel approach to imprecise assessment and decision environment) applications to energy decision-making studies are focused on the assessment of scenarios, including the feasibility of installing wind energy turbines on an island site, assess sustainability of bioenergy systems, assess policy measures or scenarios relating to residential heating energy and domestic electricity consumption.

VIKOR is used in applications ranging from the assessment of energy sources to energy projects and siting decision evaluations, including assessing fuel modes for public transportation, selection of renewable energy options and production sites, selection of renewable energy projects, and site selection and plant technical and operational parameters decisions of hydro power plants.

MACBETH (measuring attractiveness by a categorical based evaluation technique) is used to assess whether small scale or large scale approaches to renewable energy provision are best placed to help meet the targets set in the Energy White Paper for the UK at the lowest social, economic and environmental costs.

Participatory multi-criteria analysis is used to overcome the problems of monetary valuation and account for the multiple dimensions and long-term nature of sustainable

development, in a participatory process for appraising future energy systems.

3.3. Uncertainty

Due to the lack, inconsistency or imprecision of data and the subjectivity or vagueness of human judgments, the different types and sources of uncertainty should be explicitly taken into account to provide results in which the DM can have confidence. The difficulty of providing exact numerical values for the criteria, making precise evaluations and translating human reasoning into a qualitative/quantitative scale has been largely recognized (Doukas, 2014). Therefore, most of the input data and parameters required by the methods cannot be given precisely. Data associated with the performance of the alternatives according to multiple criteria, namely those of a more subjective nature, and parameters, such as weights whether or not understood as criterion importance coefficients, may be expressed in some methods by linguistic terms. Human judgments on qualitative attributes are always subjective and thus inherently imprecise.

Sensitivity analysis is the most popular uncertainty handling technique. Sensitivity analysis investigates the model response to different types of variation in the input information, including raw data, technical parameters conveying preferences, and additional assumptions. Several flavors of sensitivity analysis are combined with the MCDA methods mentioned above. In most applications sensitivity analysis considers changes in the results due to variations in a single parameter. Sensitivity analysis may be conducted for assessing whether there are other preferences or weights affecting the overall ordering of the options, computing the variation between optimistic and pessimistic scores, determining the range of weights within which the dominant alternative remains stable, evaluating the assignment of various criterion weighting schemes to accommodate a range of perspectives combined with different methods, studying changes of the (indifference, preference) thresholds as well as the degree of robustness for each outranking situation in ELECTRE methods. In methods based on value and utility theory approaches, the treatment of uncertainty is mainly done by using sensitivity analysis and/or stochastic distributions.

Fuzzy sets and fuzzy logic are also used to address uncertainty in MCDA. The use of fuzzy logic techniques has allowed developing a quantitative approach using a qualitative representation, so it has been capable of simultaneously handling numerical data and linguistic knowledge expression. Scenario based analysis is also a frequent uncertainty handling technique, in which a limited number of scenarios is constructed to analyze likely or relevant projections of the future. Robustness analysis, which is generally defined as the determination

of the degree to which a solution is affected, in terms of any attribute, by unknown parameters or changing assumptions, has gained an increased attention in MCDA.

4. Conclusions

The energy sector is of outstanding importance for the satisfaction of societal needs, providing directly or indirectly the fundamental requirements for almost all activities in modern societies. The application of models and methods of operational research has contributed to effective decision support in several problems arising in the energy sector. Until mid 1970s models for energy planning were mainly based on an overall cost minimization perspective subject to demand satisfaction and technology constraints. Nowadays, energy planning models, from strategic long-term to operational short-term ones, are mostly based on multi-objective optimization and multi-criteria decision analysis approaches, thus recognizing the need to encompass multiple, conflicting and incommensurate aspects of evaluation of the merits of distinct courses of action pertaining to economy, environment, reliability, quality of service, etc. These models not just capture in a more realistic manner the complexity of these problems, but also provide a value-added in exploring a variety of possible decisions representing different trade-offs between the competing objectives/criteria thus enabling a more comprehensive analysis of potential solutions also including in the decision process the preferences and interests of stakeholders.

The quest for sustainability, namely concerning renewable energy resources, technological advancements, new market designs, the significance of investments, etc., make problems in the energy sector important challenges, for which MOO and MCDA possess the right tools to be offered to planners and decision makers (governments, regulators, utilities, consumers, interest groups) for a thorough analysis and balanced recommendations. Therefore, it is expected that the energy sector will remain one of the most active and exciting areas of application of MOO/MCDA models and methods, with an enriching cross-fertilization between challenging problems and innovative models and methods.

References

Alarcon-Rodriguez, A., G. Ault, S. Galloway, Multi-objective planning of distributed energy resources: A review of the state-of-the-art, *Renewable and Sustainable Energy Reviews*, Vol. 14, n° 5, 1353–1366, 2010.

Antunes, C. H., A. G. Martins (Eds.), *OR Models for Energy Policy, Planning and Management*, *Annals of Operational Research*, Vols. 120/121, 2003.

Antunes, C. H., C. O. Henriques, *Multi-Objective Optimization and Multi-Criteria Analysis Models and Methods for Problems in the Energy Sector*. In: *Multiple Criteria Decision Analysis*, J. Figueira, S. Greco, M. Erghott (Eds.). Springer, 2014. (forthcoming)

Diakoulaki, D., C. H. Antunes, A. G. Martins. In "Multiple Criteria Decision Analysis - State of the Art Surveys", J. Figueira, S. Greco, M. Erghott (Eds.). *Int. Series in Operations Research and Management Science*, Vol. 78, 859-897, Springer, 2005.

Doukas, H., *Modelling of linguistic variables in multicriteria energy policy support*, *European Journal of Operational Research*, 2014. (forthcoming)

Greening, L., S. Bernow, *Design of coordinated energy and environmental policies: use of multi-criteria decision-making*, *Energy Policy*, Vol. 32, n° 6, 721-735, 2004.

Hobbs B, P. Meier, *Energy decisions and the environment: a guide to the use of multicriteria methods*. In: *International series in operations research and management science*. Kluwer Academic Publishers, 2000.

Løken, E., *Use of multicriteria decision analysis methods for energy planning problems*, *Renewable and Sustainable Energy Reviews*, Vol. 11, n° 7, 1584-1595, 2007.

Mirakyan, A., R. Guio, *Integrated energy planning in cities and territories: A review of methods and tools*, *Renewable and Sustainable Energy Reviews*, Vol. 22, 289-297, 2013.

Pohekar, S., M. Ramachandran, *Application of multi-criteria decision making to sustainable energy planning - A review*, *Renewable and Sustainable Energy Reviews*, Vol. 8, n° 4, 365-381, 2004.

Wang, J.-J., Y.-Y. Jing, C.-F. Zhang, J.-H. Zhao, *Review on multi-criteria decision analysis aid in sustainable energy decision-making*, *Renewable and Sustainable Energy Reviews*, Vol. 13, n° 9, 2263-2278, 2009.



MCDA Research Groups

Centre for Operational Research and Logistics (CORL)

Alessio Ishizaka
Founding Deputy Director of the CORL

The new Centre for Operational Research and Logistics (CORL) at the University of Portsmouth (UK) is gathering members of several departments: Department of Mathematics, Faculty of Technology, Operations and Systems Management Group, Portsmouth Business School and the Institute of Industrial Research, Faculty of Creative and Cultural Industries.

CORL has staff members covering many areas of the field of Operational Research and the quantitative aspects of the logistics field. There are particular strengths in the sub-fields, hereafter labelled themes, of:

1. Multiple criteria decision analysis
2. Exact methods, heuristic and metaheuristics
3. Optimisation modelling
4. Soft OR and integrated methodologies

The expertise within CORL can also be mapped onto the following target application areas:

1. Logistics, transportation, and supply chain management
2. Healthcare
3. Marine and maritime
4. Renewable energy and sustainability

These are the application areas that the Centre concentrates on building Knowledge Transfer links and applied research outputs.

In the past three years there have been a number of significant Research and KT achievements of the centre:

- Over 40 peer-reviewed ISI journal articles, the majority of which are at the ABS 3* or 4* level.
- Plenary seminars given at the International Conference on Multiple Criteria Decision Making, XV Summer School Francesco Turco "Sustainable Development: Industrial Practice, Education & Research and the Brazilian CMAC conference.
- The award of 4 PhDs including sponsored students from the Malaysian and Thai governments.
- The award of 2 major EU grants (2OM, Leanwind) and the completion of a third (SEABILLA).
- The award of a Charitable Aims project from the Operational Research Society
- The hosting of the 76th Workshop of the Euro Working Group of Multi-Criteria Decision Aid.
- Involvement in four Technology Strategy Board Projects
- Collaboration with a range of academic, research or industrial institutions worldwide

Members of CORL specialise in both discrete and continuous MCDA/M techniques. The theory and application of the distance-based MCDA/M techniques is a significant area of expertise. This involves techniques such as goal programming where the distance between a solution that can be achieved and a set of decision maker

set goals is minimised. Theoretical and computational advances in the technique of goal programming have been achieved by group members, details of most of which are available in Jones and Tamiz (2010). Distance-based MCDM/A techniques have been applied by CORL members to a wide range of applications including healthcare logistics and optimisation, analysis of cinema-going behaviour, fisheries economics management, selecting financial portfolios, and location of offshore wind-farms.

The second major area of expertise of CORL members is that of discrete decision aiding methods (Ishizaka and Nemery 2013), where we are active on the whole spectrum of the discrete MCDA methodologies, including aggregation methods (AHP, ANP, MacBeth, UTA), outranking methods (ELECTRE, PROMETHEE, GAIA), performance evaluation (DEA), case-based decision analysis (IRIS), decision rule methods (DRSA), robust ordinal regression and non-additive integrals to represent interaction between criteria (e.g. Choquet integral), interactive multiobjective optimization methods. We apply all these MCDA methodologies for choice, ranking, sorting decision problems, both in case of a single decision maker or group of decision makers.

References:

Ishizaka, A and Nemery, P (2013) Multicriteria decision analysis: methods and software. Wiley, Chichester. ISBN 9781119974079

Jones, DF and Tamiz, M (2010) Practical Goal Programming, Springer Books, New York.

The current members of the CORL are:

- Professor Dylan Jones (Director)
- Dr Alessio Ishizaka (Deputy Director)
- Dr Maria Barbatti
- Dr Philip Brabazon
- Professor David Brown
- Dr Huijing Chen
- Professor Salvatore Greco
- Professor Ashraf Labib
- Dr Xiaodong Li
- Dr Zhening Li
- Dr Djamila Ouelhadj (KT and Application Areas Co-ordinator)
- Dr Martin Read
- Dr Jana Ries (Events Co-ordinator)
- Dr Edward Smart
- Dr Xiang Song (Themes Co-ordinator)
- Dr Graham Wall
- Dr Christine Welch
- Dr Salem Chakhar
- Dr Saijd Siraj

More information on the CORL can be found on <http://www.port.ac.uk/corl>

Consultancy Company



Enrico Rigoni, Mauro Murerato
ESTECO SpA
AREA Science Park
Padriciano 99,
34149 Trieste ITALY
Building L2

Phone: +39 040 3755548
Fax: +39 040 3755549
mail: rigoni@esteco.com, murerato@esteco.com

ESTECO is known as a pioneer in numerical optimization solutions, specialized in the research and development of engineering software for all stages of the simulation-driven design process. ESTECO caters to engineers and researchers across a wide range of sectors including the automotive, aerospace, manufacturing, pharmaceutical, petrochemical and life sciences industries. ESTECO S.p.A. headquarters have been located at the AREA Science Park of Trieste (Italy) since the very beginning, and along the way, the initial group of experts in optimization techniques, numerical analysis and information technology has grown and acquired new skills, positioning ESTECO as the ideal partner for engineering companies interested in optimizing the industrial design process. Today ESTECO has more than 50 employees – most of them engineers and IT specialists – in Italy, USA (an ESTECO subsidiary) and India, and is distributed throughout Europe, South America and Asia via a qualified network of partners.



modeFRONTIER®, the company's key product, is an integration platform for multi-objective and multi-disciplinary optimization. It provides seamless coupling with third party engineering tools, enables the automation of the design simulation process, and facilitates analytic decision making. With modeFRONTIER®, the design process is streamlined, combining the different design objectives of individual engineering disciplines. Powerful workflows enable the execution of complex chains of design optimization, innovative algorithms determine the set of best possible solutions combining opposing objectives, and post-processing tools allow users to perform sophisticated statistical analysis and data visualization, actively supporting the decision making process.

Advanced Optimization and Numerical Tools

ESTECO expertise in numerical solutions equips designers with a complete array of optimization algorithms covering deterministic, stochastic and heuristic methods for both single and multi-objective problems. Alongside traditional methods, modeFRONTIER provides fine-tuned multi-strategy optimization algorithms able to multiply the capabilities of single approaches: the FAST algorithm (using Response Surface Methodology to accelerate the number of iterations to achieve the optimum), the Hybrid method (combining global search and local refinement) and SAnGeA (adding an automatic screening phase to manage high-dimension, unconstrained problems). For post processing purposes, modeFRONTIER® provides a comprehensive environment for data analysis and visualization, enabling the statistical assessment of complex datasets. These sophisticated tools, ranging from Sensitivity Analysis to Multi-Variate and Visual Analysis, help visualize results from multiple simulations and identify key problems.

MCDM in modeFRONTIER

When design problems reach a certain level of complexity, a visual classification of the options becomes unfeasible. When many competing objectives apply, modeFRONTIER® users can automate the ranking of alternatives when intuition alone cannot provide a rational order.

Example of modeFRONTIER workflow

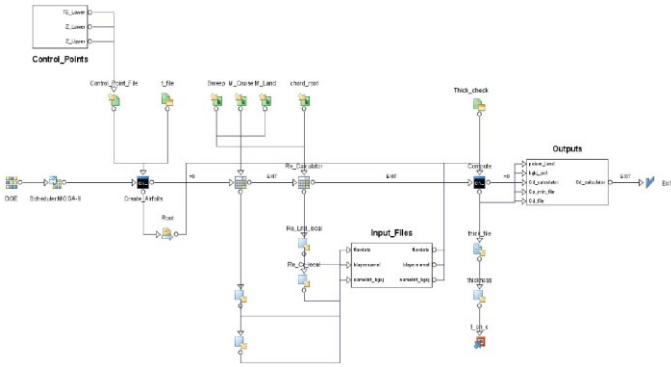

ESTECO customer, Alenia Aermacchi, used modeFRONTIER to optimize the wing of an aircraft and, with the help of the MCDM tool, successfully identified the most environmentally-friendly wing configuration.

Aircraft view

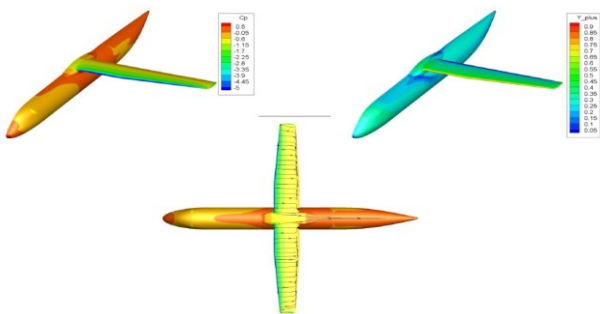

Starting from a reference configuration, designers followed a two-step approach:
1. Increment the aerodynamic performance

2. Reduce the wing weight while maintaining the optimal aerodynamic settings among those identified.

The modeFRONTIER® optimization process starts from the creation of the workflow where users define all input variables, objectives and parameters. The optimization algorithm selected was the genetic method MOGA-II which generated 20k possible designs; 3k Pareto designs were then extracted from this design dataset. But which design was effectively the best given the constraint and objectives?

Alenia Aermacchi performed a Multiple Criteria Decision Making (MCDM) process, using the modeFRONTIER MDM tool. After evaluating the available modeFRONTIER algorithm sets, Alenia Aermacchi engineers used the GA-MCDM. Since it was hard to define the weights of the utility function precisely, this algorithm provided a full ranking without specifying the function parameters, indicating the importance of one criterion with respect to others. As a result of this guided decision-making process, the aerodynamic performance of the wing design was enhanced by 2.5%, with a 4% wing weight reduction.

modeFRONTIER GA-MCDM Panel

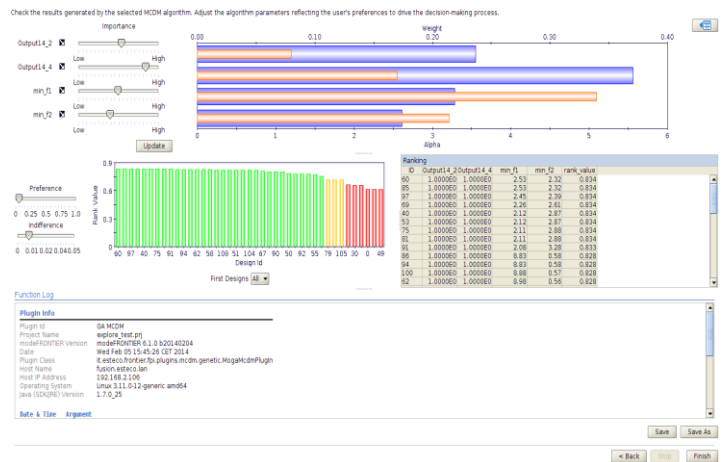

The main benefit of using the modeFRONTIER MCDM tool consists in the capability of investigating a series of possible rankings simply by changing a few parameters and, in doing so, find the most reliable solution. When engineers deal with a large set of possible solutions, it becomes very important to have a fast tool which is able to rank a large number of designs almost instantaneously without having a constrained tool and allows users to explore all ranking solutions quickly and efficiently.

Example of Design Space results

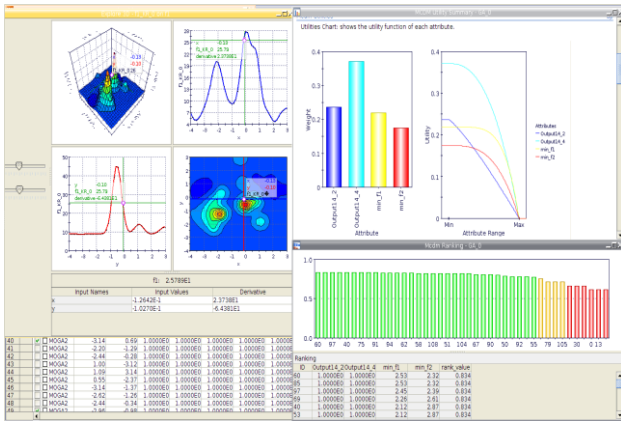

Software

Smart-Picker Pro Software

The Promethee and FlowSort methods to address choice, ranking, sorting and description problems.

Ph. Nemery

www.smart-picker.com ; philippe@smart-picker.com

Smart-Picker Pro is a decision support software that enables a decision maker to address several types of decision problems within one framework. Smart-Picker Pro helps the user when facing a choice, a ranking, a sorting and/or a description problem involving several criteria. Smart-Picker Pro implements therefore the PROMETHEE and GAIA [1] and FlowSort [2] methods along with weight elicitation methods. The decision maker or practitioner needs in fact to get used to only one method to solve all type of problems within the user-friendly software, described in this article. Introduction

1. Introduction

On any one day, people face a plethora of different decisions and people face no longer one specific type of decision problem. A manager in a company for example may have to evaluate projects and regroup them in priority-based categories along with the required resources (human, financial, equipment ...). Besides, he might have to hire new workforce and choose the best candidate(s) amongst a group of potential persons. The manager will regularly evaluate suppliers and develop partnerships with the best ones. Understanding the weaknesses and strengths of each team member will help the manger to develop the team's skills with a personal development plan and assigning adequately corresponding tasks.

People and companies consider multiple (often conflicting) criteria in their decision process to build long-term relationships, make sustainable and environmentally friendly decisions. Furthermore, decision problems arise frequently; they are diverse and have to be addressed in a minimum of time. In order to support the practitioner, Smart-Picker has developed a software package which integrates several methods within a unified framework [3] (to reduce the learning curve and increase its use).

Visualization [4] and user-friendliness have been one of the major focuses of the software. In what follows, a particular attention will be paid to visualizations within the sorting context although similar visualizations exist for ranking problem.

The reader can find more information in our co-written book 'Multi-Criteria Decision Analysis: Methods and Software' [5] as well as in the manual [6]. Let us mention that there is a trial version and license fees can be negotiated for academic and business users.

2. Sorting: FlowSort

Smart-Picker Pro supports the sorting method FlowSort [2] and its associated visualization tools [4]. Examples of sorting problems include regrouping of customers into 'high-value', 'medium-value' and 'low-value' customers ; the assessment of innovation capabilities of enterprises [4,7] (classified into 4 categories: proactive, pre-active, reactive and passive enterprises); assignment of projects into priority-based categories ...

The FlowSort method allows assigning a set of actions to one of K predefined categories. In the sorting context, there is a complete order on these categories such that the decision maker has ordered these categories from the best (noted C1) to the worst (CK).

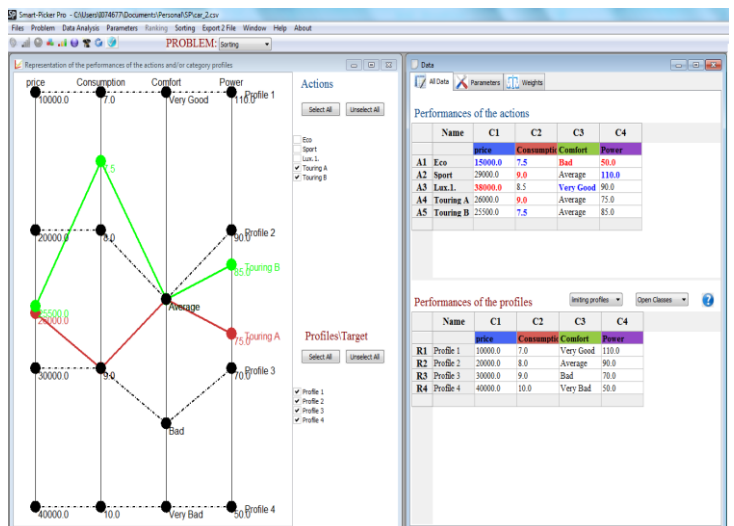

Figure 1 Representation of a sorting problem with 5 actions to be assigned to 3 categories defined by limiting profiles.

The categories are predefined since the decision maker knows their exact meaning. Therefore, he defines the categories by means of either limiting (boundary) profiles or central (representative) profiles. Figure 1 represents the problem definition phase: the sorting of 5 cars ('Eco', 'Touring A', 'Touring B', 'Lux.1' and 'Sport'), evaluated on 4 criteria (price, consumption, comfort and power), into 3 categories (the most preferred cars, the cars to be further investigated and the least preferred cars) defined by limiting profiles.

The FlowSort method is a direct extension of the PROMETHEE method and is based on the following idea: in order to assign an action to a category, it compares the action to the profiles by means of the PROMETHEE ranking method and then deduces its category based on its rank. All the actions, which belong to the same category, will receive the same recommendation. It is important to remark that the assignment of one action into one of the categories is independent from the assignment of the other actions.

Figure 3 represents therefore the comparison (in terms of net flows) of the car 'Sport' with the reference profiles (based on the net flows). Once the action assigned to its category, the decision maker is willing to understand the (reason of) assignment: the user can directly notice that 'Sport' is assigned to the second category due to a high score on 'Power' but with comparatively weaker scores on 'Consumption'.

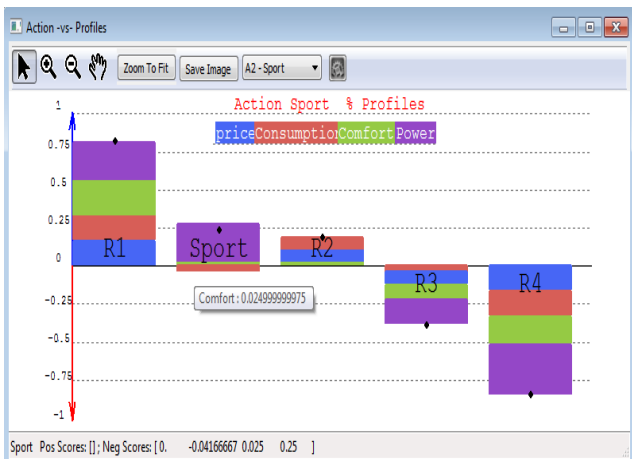

Figure 2 Comparison of an action (Sport car) to the reference profiles R1-R4.

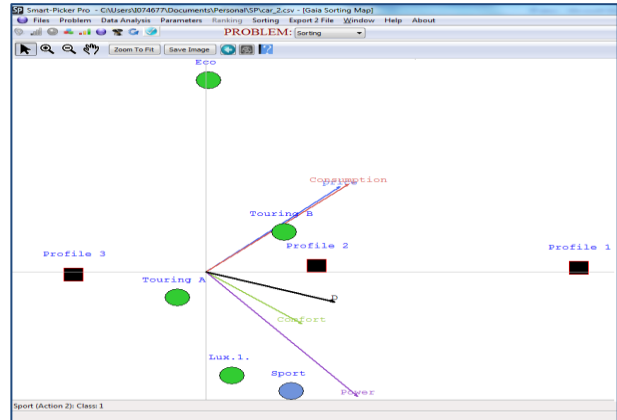

Figure 3 Assignment of all actions.

Furthermore, although the assignment of an action is independent of the other actions, the decision maker is usually interested in analyzing the similarities and differences between assigned actions. Figure 3 and Figure 4 (the so-called FS-Gaia plane [4]) permit to answer the following questions very easily:

- Why are some actions assigned to different classes (e.g. 'Lux.1' and 'Sport'?)
- Do the actions, assigned to the same category, have similar or different evaluations (e.g. 'Eco' and 'Touring A')?

Let us finally remark that all the parameters of the sorting methods such as the weights (that can be defined by means of an elicitation process), the thresholds, etc. can easily be varied in order to perform a sensitivity analysis.

Finally, as shown in Figure 5, the user can increase/decrease the evaluation of an action on one criterion in order to investigate when a change in assignment will occur. If the 'power' of 'Eco' becomes 90.8 instead of 50, 'Eco' will be assigned to class 1 instead of the 2nd class.

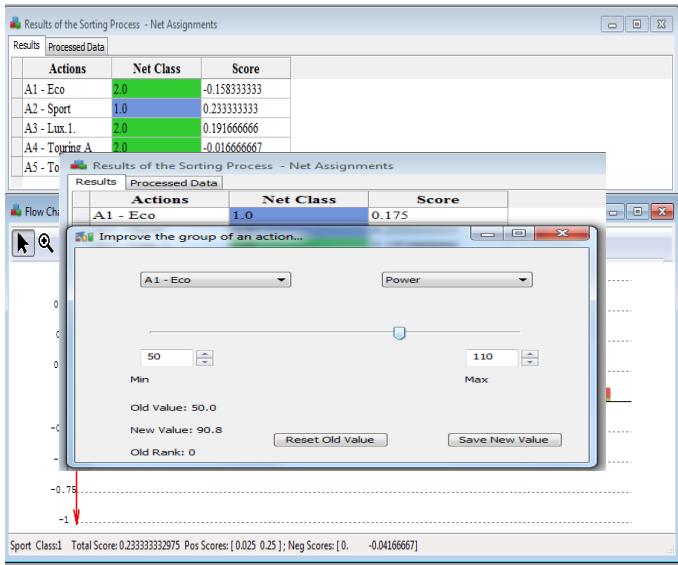

Figure 5 Improvement of the assignment of an action

3. Ranking: Promethee

Smart-Picker Pro implements the Promethee-GAIA Method to address the ranking, choice and description problem. Figure 6 shows the usual steps involved in the Promethee method: defining the preference parameters such as the preference function, the thresholds and the weights.

On the right, the user will see the final ranking of the actions along with the classic Gaia map. Let us remark that the user has indeed access to all the intermediate scores (net, positive, negative flows and all unit-criterion scores) and can perform a sensitivity analysis by changing the values of each parameter and seeing the impact visually. Figure 6 Implementation of the Promethee method

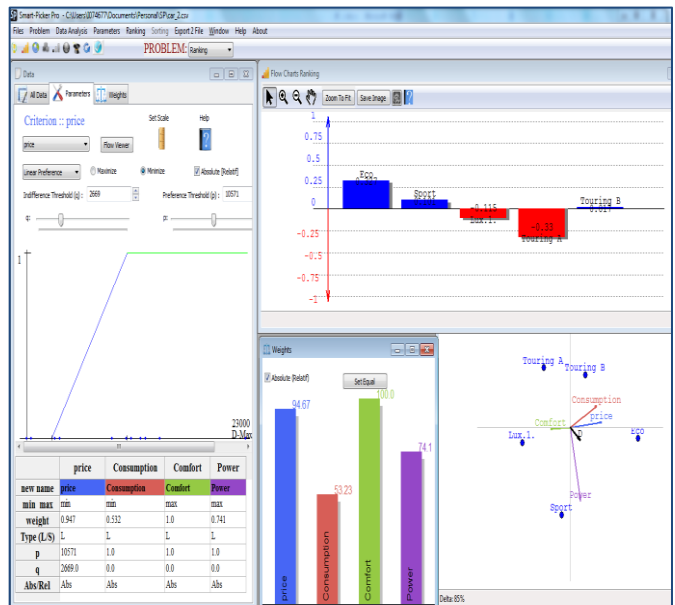

Figure 6 Implementation of the Promethee Method

References

1. Brans, J., and Vincke, P. (1985). A preference ranking organization method: The Promethee method for multiple criteria decision making. *Management Science*, 31, 647–656.
2. Nemery, P., and Lamboray, C. (2008). FlowSort: a flow-based sorting method with limiting or central profiles. *TOP*, 16(1), 90–113.
3. Nemery, P., Mareschal, B., and Ishizaka, A. (2010). Unification of problem formulation with PROMETHEE, Keynote Paper. The 52th Operational Research Society Conference (pp. 60–72). London.
4. Nemery, P., Ishizaka, A., Camargo, M., and Morel, L. (2012). Enriching descriptive information in ranking and sorting problems with visualizations techniques. *Journal of Modelling in Management*, 7(2), 130–147.

5. Ishizaka A. and Nemery Ph. (2013). *Multi-Criteria Decision Analysis: Methods and Software*. Chichester: John Wiley and Sons, Ltd.

6. Smart-Picker (2012): <http://www.smart-picker.com/help/index.html>

7. Innovation on the web: <http://innovation-on-the-web.com/>.

About the 79th Meeting

National Centre for Scientific Research "DEMOKRITOS", Athens, GREECE, 3rd to 5th April 2014

The 79th meeting of the European Working Group on Multicriteria Decision Aiding has taken place at the National Centre for Scientific Research "DEMOKRITOS", in Athens, GREECE, from the 3rd to the 5th April 2014. The 79th MCDA Meeting has specially focused on the "Multicriteria decision support in emergency and land use planning", as Risk management, i.e. the lowering of the individual risk created by a hazardous installation, constitutes a central factor affecting the acceptability of the latter by the nearby communities. It has been widely recognized that people accept technology mainly because of the benefits they can derive, while in the siting procedure of a potentially noxious facility or in the routing selection of hazardous materials transportation, the "not-in-my-back-yard" (NIMBY) syndrome is very difficult to ignore in wealthy western societies.

MCDA is more related to the risk perception by the general public caused by both natural and technological hazards; namely the former will aid in the decision making among various alternatives." In this perspective, the 79th meeting of the European Working Group on Multicriteria decision aiding has hosted contributions that gave some illuminating answers to these questions.

Articles presented

In total, 22 abstracts have been submitted, with 15 of them presented as short (20') presentations and 2 as long (40') ones; the rest have been announced as "discussion papers" and all abstracts have been included in the relevant book of Abstracts. The themes of the sessions included "Land Use Planning", "Resources Planning", "Robustness & multi-objective optimization", "Hierarchy process", "Finance" and "Ranking methods". There has also been a) a special session dedicated to the 80th anniversary of Bernard Roy, the founder of the MCDA group, and b) a round table session dedicated to "Ordinal Regression".

Participants

Around 50 participants have been registered to the workshop (and almost all of them came to the meeting), participating vividly in the discussion after each presentation. Additionally, a group of 20 students in informatics joined the workshop to follow the concluding remarks of it on the second day. A number of 30 regular

members of the group send their registration without participating in this workshop so as to continue to be members of the group.

Social program

On the first day of the meeting a common dinner has been organized in a typical Greek tavern. On the second day a common supper has been also organized for most of the participants, while on the 3rd day an excursion to the archaeological site of Sounion (near Athens) has taken place, followed by a lunch by the seaside.

79e Journées du Groupe de Travail Européen «Aide Multicritère à la Décision» 79th Meeting of the European Working Group «Multiple Criteria Decision Aiding» (Athens, Greece 3-5 avril/April, 2014)

SCIENTIFIC PROGRAM / PROGRAMME SCIENTIFIQUE

Program

Day 1: Thursday 3th April 2014

11:30 – 12:45 Registration of participants

12:45 – 13:15 Welcome

13:15 – 14:30 Session 1 – Land Use Planning

Chair: Zoe Nivolianitou

13:15 – 13:40 Assessment of vulnerability of land-use types with respect to major accident hazards

Ioannis Sebos, Athena Progiou, Ioannis Ziomas

13:40 – 14:05 Sustainability assessment in rural urban fringe areas: A proposed methodology

Ottomano Palmisano G., De Boni A., Roma R.

14:05 – 14:30 Exploring the role of artificial neural networks for the multidimensional evaluation of territorial vulnerability and local conflicts

Alessandra Oppio, Stefano Corsi, Andrea Tosini

14:30 – 15:20 Session 2 – Resources Planning

Chair: José Rui Figueira

14:30 – 14:55 Multi-sensor Fusion - An application to the Food Industry

Loukas, D., & Nychas, G-J

14:55 – 15:20 Interactive Multiobjective Optimization using Dominance-based Rough Set Approach

Salvatore Greco, Benedetto Matarazzo, Roman Słowiński
Discussion papers

1. Multicriteria Assessment of Agricultural Resources for Energy and Material Use

Meike Schmebla, Jutta Geldermann

15:20 – 16:00 Coffee break

16:00 – 17:30 Session 3 - Session dédiée à Bernard Roy/Session dedicated to Bernard Roy

Chair: Yannis Siskos

16:00 – 16:30 ELECTRE: A comprehensive literature review on methodologies and applications

Kannan Govindan, Martin Brandt Jepsen

16:30 – 17:30 Présentation de Bernard Roy à l'occasion de ses 80 ans (album photos + vidéos)
Yannis Siskos, Nikolaos Matsatsinis
17:30 End of day 1

20:00 – 23:00 Official Dinner in Athens

Day 2: Friday 4th April 2014

9:15 – 10:30 Session 4 – Robustness and multiobjective optimization

Chair: Constantin Zopounidis

9:15 – 9:40 Inducing probability distributions on the set of value functions

Salvatore Corrente, Salvatore Greco, Milosz Kadziński, Roman Słowiński

9:40 – 10:05 Generalizing the core concept for multi-objective multi-dimensional knapsack problems and comparison to evolutionary algorithms

George Mavrotas, José Rui Figueira, Kostas Florios

10:05 – 10:30 Measuring the robustness of Pareto sets in multi-objective integer programming problems

George Mavrotas, José Rui Figueira, Eleftherios Siskos

Discussion papers

1. Aide à la décision robuste dans une démarche de développement durable

Bastien Rizzon, Vincent Clivillé, Sylvie Galichet

2. Applying stochastic MUSA for the evaluation of hotel service quality

E. Grigoroudis

10:30 – 11:00 Coffee break

11:00 – 11:30 Presentation of next meetings

Irène Abi-Zeid, Vincent Clivillé

11:30 – 12:20 Session 5 – Hierarchy process

Chair: Michael Doumpos

11:30 – 12:00 Applying Multiple Criteria Hierarchy Process to UTADIS and UTADISGMS

Salvatore Corrente, Michael Doumpos, Salvatore Greco, Roman Słowiński, Constantin Zopounidis

11:00 – 12:20 Multiple Criteria Hierarchy Process applied to decision about the re-use of historical buildings

Bottero M., Corrente S., Ferretti V., Greco S., Słowiński R.

Discussion papers

1) ELECTRE-TRI-B-H for solving hierarchically structured sorting problems

Luis Del Vasto-Terrientes, Aida Valls, Piotr Zielniewicz

12:20 – 12:50 Round table – Ordinal Regression

12:50 – 14:00 Lunch break

14:00 – 15:15 Session 6 – Finance

Chair: Salvatore Greco

14:00 – 14:45 Project portfolio selection for group decision making using multi-criteria analysis and mathematical programming through an iterative approach

Olena Pechak, George Mavrotas, Danae Diakoulaki, John Psarras

14:45 – 15:15 Towards a robust multiple criteria aggregation procedure for mixed evaluations

Sarah Ben Amor

Discussion papers

1. How to evaluate social innovation. A multicriteria approach

Maria A. de Vicente, María Alvarado, Ricardo García Vegas, Jaime Manera

2. Was the Construction Sector in 20 European Countries Anti-Cyclical during the Recession Years 2008-2009 as measured by MOO?

Willem K. M. Brauers and Edmundas K. Zavadskas

15:15 – 15:45 Coffee break

15:45 – 17:30 Session 7 – Ranking methods

Chair: Roman Słowiński

15:45 – 16:10 Parametric evaluation of research units with respect to reference profiles

Milosz Kadziński, Roman Słowiński

16:10 – 16:35 Proposition d'un cadre de prise de décision pour la conservation de rang d'une classe:

Examen de quelques méthodes multicritères

Amine Affes, Abdelwaheb Rebai

Discussion papers

1. Data-driven robustness analysis for MCDA preference disaggregation approaches

Michael Doumpos, Constantin Zopounidis

2. The Chance Constrained Recourse Approach for Portfolio Selection

Fouad Ben Abdelaziz and Meryem Masmoudi

16:35 – 17:30 Concluding remarks

17:30 End of day 2

20:00 – 23:00 Optional Dinner in Athens

Day 3: Saturday 5th April 2014

9:30 – 17:00 Excursion to Sounion

Official Dinner, Thursday: CHRISOMILO, 12, Agatharchou str. & Lepeniotou, Psiri, MONASTIRAKI metro station (on the map signed with "A")

Optional Dinner, Friday: YRIA, 6, Herakleidon str., close to the pedestrian road (Apostolou Pavlou) to Acropolis (on the map signed "STAVLOS")

Forthcoming meetings

IFORS 2014 - 20th Conference of the International Federation of Operational Research Societies
Barcelona, Spain
<http://www.ifors2014.org>

19/7/2014-1/8/2015
EURO Summer Institute 2014. OR in Agriculture and Agrifood Industry
Lleida, Spain
http://orafm.udl.cat/?page_id=233

20-25/7/2014
WCCM 2014 - 11th World Congress on Computational Mechanics
Barcelona, Spain
<http://www.wccm-eccm-ecfd2014.org>

20-25/7/2014
ORAHS 2014 - Operational Research Applied to Health Services
Lisbon, Portugal
<http://www.orahs2014.fc.ul.pt>

28-30/7/2014
Optimization 2014
Guimarães, Portugal
<http://optimization2014.dps.uminho.pt>

29-31/7/2014
6th International Conference on Applied Operational Research - ICAOR 2014
Vancouver, Canada
<http://www.tadbir.ca>

24-29/8/2014
19th IFAC World Congress IFAC 2014
Cape Town, South Africa
<http://www.ifac2014.org/>

26-29/8/2014
PATAT 2014 - 10th International Conference on the Practice and Theory of Automated Timetabling
York, United Kingdom
<http://www.patatconference.org/patat2014/>

2-5/9/2014
International Conference on Operations Research, OR2014
Aachen, Germany
<http://www.or2014.de>

8-11/9/2014
EngOpt 2014 - 4th International Conference on Engineering Optimization
Lisbon, Portugal

<http://www.dem.ist.utl.pt/engopt2014>

10-12/9/2014
ANTS 2014 - Ninth International Conference on Swarm Intelligence
Brussels, Belgium
<http://iridia.ulb.ac.be/ants2014>

24-26/9/2014
The 15th International Conference on Operational Research KOI 2014
Osijek, Croatia
<http://www.hdoi.hr/en/call-for-papers>

Autumn 2014
80th EWG on MCDA
Québec (Canada)

27-31/10/2014
META'2014 - International Conference on Metaheuristics and Nature Inspired Computing
Marrakech, Morocco
<http://meta2014.sciencesconf.org/>

9-12/11/2014
INFORMS Annual Meeting 2014
San Francisco, USA
<http://meetings2.informs.org/sanfrancisco2014/>

3-7/8/2015
23rd International Conference on Multiple Criteria Decision Making MCDM 2015
Hamburg, Germany
<http://www2.hsu-hh.de/logistik/MCDM-2015/>

October 6-9, 2013
INFORMS Annual Meeting 2013 Minneapolis
Minneapolis Convention Center & Hilton Minneapolis, USA
<http://www.informs.org>

The 36th Annual Meeting of the Society for Medical Decision Making
October 19-24, 2014
Doral Golf Resort and Spa, USA
http://smdm.org/smdm_annual_meetings.shtml

INFORMS Annual Meeting 2014 San Francisco
November 16-19, 2014
Hilton San Francisco, USA
<http://www.informs.org>

Announcements and Call for Papers

Below you can find the link for the new issue of our IJMCDM.

<http://www.inderscience.com/info/inarticletoc.php?jcode=jmcdm&year=2014&vol=4&issue=2>

EURO Mini Conference on
Improving Healthcare: new challenges, new approaches
Coimbra, Portugal
30 March – 1 April 2015
www.minieuro2015.com

Streams

If you are interested in organizing a stream please let us know (info@minieuro2015.com).

Confirmed streams:

- Health Informatics
- Radiotherapy Optimization
- Biomedicine
- Health Logistics and Scheduling
- Health Economics

Important Dates:

Submission of Abstracts/ Papers: 17 October 2014
Notification of acceptance: 15 December 2014
Final abstract/paper due: 09 February 2015
Early Registration Deadline: 02 March 2015

Master «Modeling, Optimization, Decision, Organization (MODO)»

Université Paris-Dauphine, Ecole des Mines de Paris

This one-year Master Programme (level M2), which has been existing and evolving for about 40 years, is devoted to Decision Aiding and Operational Research.

Starting next academic year (2014-2015), courses will be taught in the English language and the programme will be organized around three main streams. In particular, the « Decision » stream includes courses such as Decision Theory and Game Theory, Multiobjective Optimization, Robustness in Operational Research and Decision Aiding, Algorithmic Decision Theory and Computational Social Choice.

Tuition fees are around 500 euros per year.

More information about the programme including the application procedure can be found at

<http://modo.dauphine.fr/en/master-program.html>

Any inquiries about the master can be addressed at master-modo@dauphine.fr

Web site for Announcements and Call for Papers:

www.cs.put.poznan.pl/ewgmcdm

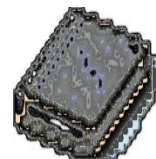

Books

Multicriteria Analysis in Finance

By Doumpos, Michael, Zopounidis, Constantin, Springer 2014.

This book provides a concise introduction into the fundamentals and applied techniques of multiple criteria decision making in the finance sector. Based on an analysis of the nature of financial decisions and the general methods of financial modelling, risk management and financial engineering, the book introduces into portfolio management, banking management and credit scoring. Finally the book presents an overview of further applications of multi criteria analysis in finance and gives an outlook on future perspectives for the application of MCDA in finance.

<http://www.springer.com/business+%26+management/operations+research/book/978-3-319-05863-4>



Articles Harvest

(This section is prepared by Salvatore CORRENTE, salvatore.corrente@unict.it)

Abastante, F., Bottero, M., Greco, S., Lami, I. (2014). Addressing the location of undesirable facilities through the dominance-based rough set approach. *Journal of Multi-Criteria Decision Analysis*, 21 (1-2), 3-23.

Abdelaziz, F.B., Masmoudi, M. (2013). A multiple objective stochastic portfolio selection problem with random Beta. *International Transactions in Operational Research*. In Press.

Aboolian, R., Cui, T., Shen, Z.-J.M. (2013). An efficient approach for solving reliable facility location models. *INFORMS Journal on Computing*, 25 (4), 720-729.

- Adlakha, V., Kowalski, K., Wang, S., Lev, B., Shen, W. (2014). On approximation of the fixed charge transportation problem. *Omega*, 43, 64-70.
- Adler, N., Hakkert, A.S., Kornbluth, J., Raviv, T., Sher, M. (2013). Location-allocation models for traffic police patrol vehicles on an interurban network. *Annals of Operations Research*. In Press.
- Adler, N., Hakkert, A.S., Raviv, T., Sher, M. (2014). The traffic police location and schedule assignment problem. *Journal of Multi-Criteria Decision Analysis*. In Press.
- Agarwal, M., Fallah Tehrani, A., Hüllermeier, E. (2014). Preference-based learning of ideal solutions in TOPSIS-like decision models. *Journal of Multi-Criteria Decision Analysis*. In Press.
- Aksin, Z., Ata, B., Emadi, S.M., Su, C.-L. (2013). Structural estimation of callers' delay sensitivity in call centers. *Management Science*, 59 (12), 2727-2746.
- Alcaide-López-De-Pablo, D., Dios-Palomares, R., Prieto, Á.M. (2014). A new multicriteria approach for the analysis of efficiency in the Spanish olive oil sector by modelling decision maker preferences. *European Journal of Operational Research*, 234 (1), 241-252.
- Alem, D., Morabito, R. (2013). Risk-averse two-stage stochastic programs in furniture plants. *OR Spectrum*, 35 (4), 773-806.
- Alfian, G., Rhee, J., Yoon, B. (2014). A simulation tool for prioritizing product-service system (PSS) models in a carsharing service. *Computers & Industrial Engineering*, 70, 59-73.
- Alirezazadeh, P., Boylu, F., Garfinkel, R., Gopal, R., Goes, P. (2014). Identity matching and information acquisition: Estimation of optimal threshold parameters. *Decision Support Systems*, 57, 160-171.
- Amaldi, E., Coniglio, S., Gualandi, S. (2014). Coordinated cutting plane generation via multi-objective separation. *Mathematical Programming*, 143 (1-2), 87-110.
- Amorim, P., Almada-Lobo, B. (2014). The impact of food perishability issues in the vehicle routing problem. *Computers & Industrial Engineering*, 67, 223-233.
- Andersson, T., Andersson, C., Talman, A.J.J. (2013). Sets in excess demand in simple ascending auctions with unit-demand bidders. *Annals of Operations Research*, 211 (1), 27-36.
- Andriosopoulos, K., Nomikos, N. (2014). Performance replication of the Spot Energy Index with optimal equity portfolio selection: Evidence from the UK, US and Brazilian markets. *European Journal of Operational Research*, 234 (2), 571-582.
- Annie Francie, K., Jean-Pierre, K., Pierre, D., Victor, S., Vladimir, P. (2014). Stochastic optimal control of manufacturing systems under production-dependent failure rates. *International Journal of Production Economics*, 150, 174-187.
- Aouni, B., Colapinto, C., La Torre, D. (2014). Financial portfolio management through the goal programming model: Current state-of-the-art. *European Journal of Operational Research*, 234 (2), 536-545.
- Aparicio, J., Pastor, J.T. (2014). Closest targets and strong monotonicity on the strongly efficient frontier in DEA. *Omega*, 44, 51-57.
- Aşkan, A., Sayin, S. (2013). SVM classification for imbalanced data sets using a multiobjective optimization framework. *Annals of Operations Research*. In Press.
- Askar, S.S. (2014). Complex dynamic properties of Cournot duopoly games with convex and log-concave demand function. *Operations Research Letters*, 42 (1), 85-90.
- Asmild, M., Hougaard, J.L., Kronborg, D. (2013). Do efficiency scores depend on input mix? A statistical test and empirical illustration. *Annals of Operations Research*, 211 (1), 37-48.
- Atahran, A., Lenté, C., T'kindt, V. (2014). A multicriteria dial-a-ride problem with an ecological measure and heterogeneous vehicles. *Journal of Multi-Criteria Decision Analysis*. In Press.
- Ayanso, A., Goes, P.B., Mehta, K. (2014). Range query estimation with data skewness for top-k retrieval. *Decision Support Systems*, 57, 258-273.
- Bagchi, P., Lejeune, M.A., Alam, A. (2014). How supply competency affects FDI decisions: Some insights. *International Journal of Production Economics*, 147 (B), 239-251.
- Baldiga, K. (2014). Gender differences in willingness to guess. *Management Science*, 60 (2), 434-448.
- Balla, V., Gaganis, C., Pasiouras, F., Zopounidis, C. (2014). Multicriteria decision aid models for the prediction of securities class actions: Evidence from the banking sector. *OR Spectrum*, 36 (1), 57-72.
- Bana e Costa, C.A., Lourenço, J.C., Oliveira, M.D., Bana e Costa, J.C. (2014). A Socio-technical Approach for Group Decision Support in Public Strategic Planning: The Pernambuco PPA Case. *Group Decision and Negotiation*, 23 (1), 5-29.

Bandyopadhyay, S., Maulik, U., Coello, C.A.C., Pedrycz, W. (2014). Guest editorial: Special issue on advances in multiobjective evolutionary algorithms for data mining. *IEEE Transaction on Evolutionary Computation*, 18 (1), 1-3.

Batta, R., Lejeune, M., Prasad, S. (2014). Public facility location using dispersion, population, and equity criteria. *European Journal of Operational Research*, 234 (3), 819-829.

Bayraktar, E., Tatoglu, E., Zaim, S. (2013). Measuring the relative efficiency of quality management practices in Turkish public and private universities. *Journal of the Operational Research Society*, 64 (12), 1810-1830.

Beck, B., Iversen, P., Sashegyi, A. (2014). Combining Information for Quantitative Decision-making in Drug Development. *Journal of Multi-Criteria Decision Analysis*. In Press.

Bellantuono, N., Ettorre, D., Kersten, G.E., Pontrandolfo, P. (2013). Multi-attribute Auction and Negotiation for e-Procurement of Logistics. *Group Decision and Negotiation*. In Press.

Bento, G.C., Cruz Neto, J.X., Oliveira, P.R., Soubeyran, A. (2014). The self regulation problem as an inexact steepest descent method for multicriteria optimization. *European Journal of Operational Research*, 235 (3), 494-502.

Berghman, L., Leus, R., Spieksma, F.C.R. (2014). Optimal solutions for a dock assignment problem with trailer transportation. *Annals of Operations Research*, 213 (1), 3-25.

Bersimis, S., Koutras, M.V., Maravelakis, P.E. (2014). A compound control chart for monitoring and controlling high quality processes. *European Journal of Operational Research*, 233 (3), 595-603.

Bertsimas, D., O'Hair, A. (2013). Learning preferences under noise and loss aversion: An optimization approach. *Operations Research*, 61 (5), 1190-1199.

Bi, J., Meng, Q., Zhang, Y. (2014). Dynamic mean-variance and optimal reinsurance problems under the no-bankruptcy constraint for an insurer. *Annals of Operations Research*, 212 (1), 43-59.

Bianchessi, N., Mansini, R., Speranza, M.G. (2014). The distance constrained multiple vehicle traveling purchaser problem. *European Journal of Operational Research*, 235 (1), 73-87.

Bilal, N., Galinier, P., Guibault, F. (2014). An iterated-tabu-search heuristic for a variant of the partial set covering problem. *Journal of Heuristics*, 20 (2), 143-164.

Bilgen, B., Çelebi, Y. (2013). Integrated production scheduling and distribution planning in dairy supply chain by hybrid modelling. *Annals of Operations Research*, 211 (1), 55-82.

Bisdorff, R., Meyer, P., Veneziano, T. (2014). Elicitation of criteria weights maximising the stability of pairwise outranking statements. *Journal of Multi-Criteria Decision Analysis*, 21 (1-2), 113-124.

Bish, D.R., Sherali, H.D., Hobeika, A.G. (2014). Optimal evacuation planning using staging and routing. *Journal of the Operational Research Society*, 65 (1), 124-140.

Blöchliger, I., Zufferey, N. (2013). Multi-coloring and job-scheduling with assignment and incompatibility costs. *Annals of Operations Research*, 211 (1), 83-101.

Blome, C., Schoenherr, T., Eckstein, D. (2014). The impact of knowledge transfer and complexity on supply chain flexibility: A knowledge-based view. *International Journal of Production Economics*, 147 (B), 307-316.

Bonnell, H., Collonge, J. (2013). Stochastic Optimization over a Pareto Set Associated with a Stochastic Multi-Objective Optimization Problem. *Journal of Optimization Theory and Applications*. In Press.

Bottero, M., Ferretti, V., Pomarico, S. (2014). Assessing different possibilities for the reuse of an open-pit quarry using the choquet integral. *Journal of Multi-Criteria Decision Analysis*, 21 (1-2), 25-41.

Bounhas, M., Ghasemi Hamed, M., Prade, H., Serrurier, M., Mellouli, K. (2014). Naive possibilistic classifiers for imprecise or uncertain numerical data. *Fuzzy Sets and Systems*, 239, 137-156.

Boylan, J.E., Chen, H., Mohammadipour, M., Syntetos, A. (2014). Formation of seasonal groups and application of seasonal indices. *Journal of the Operational Research Society*, 65 (2), 227-241.

Bozóki, S., Dezsó, L., Poesz, A., Temesi, J. (2013). Analysis of pairwise comparison matrices: An empirical research. *Annals of Operations Research*, 211 (1), 511-528.

Bozorgi-Amiri, A., Jabalameli, M.S., Mirzapour Al-e-Hashem, S.M.J. (2013). A multi-objective robust stochastic programming model for disaster relief logistics under uncertainty. *OR Spectrum*, 35 (4), 905-933.

Brandenburg, M., Govindan, K., Sarkis, J., Seuring, S. (2014). Quantitative models for sustainable supply chain

management: Developments and directions. *European Journal of Operational Research*, 233 (2), 299-312.

Bratus, A., Todorov, Y., Yegorov, I., Yurchenko, D. (2013). Solution of the Feedback Control Problem in the Mathematical Model of Leukaemia Therapy. *Journal of Optimization Theory and Applications*, 159 (3), 590-605.

Brockhoff, D., Bader, J., Thiele, L., Zitzler, E. (2013). Directed multiobjective optimization based on the weighted hypervolume indicator. *Journal of Multi-Criteria Decision Analysis*, 20 (5-6), 291-317.

Brofman Epelbaum, F.M., Martinez, M.G. (2014). The technological evolution of food traceability systems and their impact on firm sustainable performance: A RBV approach. *International Journal of Production Economics*, 150, 215-224.

Brownlee, A.E.I., McCall, J.A.W., Zhang, Q. (2013). Fitness modeling with markov networks. *IEEE Transaction on Evolutionary Computation*, 17 (6), 862-879.

Brunelli, M., Canal, L., Fedrizzi, M. (2013). Inconsistency indices for pairwise comparison matrices: A numerical study. *Annals of Operations Research*, 211 (1), 493-509.

Brunner, J.O., Bard, J.F., Köhler, J.M. (2013). Bounded flexibility in days-on and days-off scheduling. *Naval Research Logistics*, 60 (8), 678-701.

Brunner, J.O., Stolletz, R. (2014). Stabilized branch and price with dynamic parameter updating for discontinuous tour scheduling. *Computers and Operations Research*, 44, 137-145.

Budnitzki, A. (2014). Computation of the optimal tolls on the traffic network. *European Journal of Operational Research*, 235 (1), 247-251.

Burke, E.K., Gendreau, M., Hyde, M., Kendall, G., Ochoa, G., Özcan, E., Qu, R. (2013). Hyper-heuristics: A survey of the state of the art. *Journal of the Operational Research Society*, 64 (12), 1695-1724.

Cai, S., Yang, Z. (2014). On the relationship between business environment and competitive priorities: The role of performance frontiers. *International Journal of Production Economics*, 151, 131-145.

Cailloux, O., Tervonen, T., Verhaegen, B., Picalausa, F. (2014). A data model for algorithmic multiple criteria decision analysis. *Annals of Operations Research*. In Press.

Calvo, C., Ivorra, C., Liern, V. (2014). Fuzzy portfolio selection with non-financial goals: exploring the efficient frontier. *Annals of Operations Research*. In Press.

Can, A., Ulusoy, G. (2014). Multi-project scheduling with two-stage decomposition. *Annals of Operations Research*. In Press.

Cang, S., Yu, H. (2014). A combination selection algorithm on forecasting. *European Journal of Operational Research*, 234 (1), 127-139.

Carlsson, J.G., Devulapalli, R. (2013). Dividing a territory among several facilities. *INFORMS Journal on Computing*, 25 (4), 730-742.

Carlsson, J.G., Jia, F. (2013). Euclidean hub-and-spoke networks. *Operations Research*, 61 (6), 1360-1382.

Chang, C.-C. (2014). Optimum preventive maintenance policies for systems subject to random working times, replacement, and minimal repair. *Computers & Industrial Engineering*, 67, 185-194.

Chang, C.-J., Li, D.-C., Chen, C.-C., Chen, C.-S. (2014). A forecasting model for small non-equigap data sets considering data weights and occurrence possibilities. *Computers & Industrial Engineering*, 67, 139-145.

Chang, C.-T. (2014). On product classification with various membership functions and binary behaviour. *Journal of the Operational Research Society*, 65 (1), 141-150.

Chang, L., Ouzrout, Y., Nongailard, A., Bouras, A., Jiliu, Z. (2014). Multi-criteria decision making based on trust and reputation in supply chain. *International Journal of Production Economics*, 147 (B), 362-372.

Chen, C., Liu, L.Q. (2014). Pricing and quality decisions and financial incentives for sustainable product design with recycled material content under price leadership. *International Journal of Production Economics*, 147 (C), 666-677.

Chen, C.-M. (2014). Evaluating eco-efficiency with data envelopment analysis: An analytical reexamination. *Annals of Operations Research*, 214 (1), 49-71.

Chen, L., Olhager, J., Tang, O. (2014). Manufacturing facility location and sustainability: A literature review and research agenda. *International Journal of Production Economics*, 149, 154-163.

Chen, S., Wang, H., Xie, Y., Qi, C. (2014). Mean-risk analysis of radio frequency identification technology in supply chain with inventory misplacement: Risk-sharing and coordination. *Omega*, 46, 86-103.

Chen, X., Fujita, T., Hayashi, Y., Kato, H., Geng, Y. (2014). Determining optimal resource recycling boundary at regional level: A case study on Tokyo Metropolitan

Area in Japan. *European Journal of Operational Research*, 233 (2), 337-348.

Chen, Y.-L., Cheng, L.-C., Hsu, W.-Y. (2013) A new approach to the group ranking problem: Finding consensus ordered segments from users' preference data. *Decision Sciences*, 44(6), 1091-1119.

Cheng, M., Tadikamalla, P.R., Shang, J., Zhang, S. (2014). Bicriteria hierarchical optimization of two-machine flow shop scheduling problem with time-dependent deteriorating jobs. *European Journal of Operational Research*, 234 (3), 650-657.

Cherri, A.C., Arenales, M.N., Yanasse, H.H., Poldi, K.C., Gonçalves Vianna, A.C. (2014). The one-dimensional cutting stock problem with usable leftovers - A survey. *European Journal of Operational Research*, 236 (2), 395-402.

Chhabra, M., Das, S., Sarne, D. (2014). Expert-mediated sequential search. *European Journal of Operational Research*, 234 (3), 861-873.

Chiang, T.-C., Hsu, W.-H. (2014). A knowledge-based evolutionary algorithm for the multiobjective vehicle routing problem with time windows. *Computers and Operations Research*, 45, 25-37.

Chiang, W.-C., Urban, T.L., Hu, J., (...), Xu, Y., Li, S. (2014). Interdisciplinary research in operations management. *International Journal of Production Economics*, 147 (C), 571-572.

Choi, S., Wilhelm, W.E. (2014). An approach to optimize block surgical schedules. *European Journal of Operational Research*, 235 (1), 138-148.

Choi, S., Wilhelm, W.E. (2014). On capacity allocation for operating rooms. *Computers and Operations Research*, 44, 174-184.

Chou, Y.-C., Lin, Y.-L., Chun, K.-F. (2014). A construction of knowledge rules for reactive planning of job-mix assignment to homogeneous serial batch machines. *International Journal of Production Economics*, 151, 56-66.

Chutima, P., Naruemitwong, W. (2014). A Pareto biogeography-based optimisation for multi-objective two-sided assembly line sequencing problems with a learning effect. *Computers & Industrial Engineering*, 69, 89-104.

Cire, A.A., Van Hoes, W.-J. (2013). Multivalued decision diagrams for sequencing problems. *Operations Research*, 61 (6), 1411-1428.

Claassen, G.D.H. (2014). Mixed integer (0-1) fractional programming for decision support in paper production industry. *Omega*, 43, 21-29.

Coban, E., Hooker, J.N. (2013). Single-facility scheduling by logic-based Benders decomposition. *Annals of Operations Research*, 210 (1), 245-272.

Coelho, L.C., Laporte, G. (2014). Optimal joint replenishment, delivery and inventory management policies for perishable products. *Computers and Operations Research*, 47, 42-52.

Coleman, B.J. (2014). Minimum violations and predictive meta-rankings for college football. *Naval Research Logistics*, 61 (1), 17-33.

Constantino, A.A., Landa-Silva, D., de Melo, E.L., de Mendonça, C.F.X., Rizzato, D.B., Romão, W. (2013). A heuristic algorithm based on multi-assignment procedures for nurse scheduling. *Annals of Operations Research*. In Press.

Cook, W.D., Tone, K., Zhu, J. (2014). Data envelopment analysis: Prior to choosing a model. *Omega*, 44, 1-4.

Correll, D., Suzuki, Y., Martens, B. (2014). Biorenewable fuels at the intersection of product and process flexibility: A novel modeling approach and application. *International Journal of Production Economics*, 150, 1-8.

Corrente, S., Figueira, J.R., Greco, S. (2014). Dealing with interaction between bipolar multiple criteria preferences in PROMETHEE methods. *Annals of Operations Research*. In Press.

Couceiro, M., Waldhauser, T. (2014). Pseudo-polynomial functions over finite distributive lattices. *Fuzzy Sets and Systems*, 239, 21-34.

Cox, B., Juditsky, A., Nemirovski, A. (2013). Dual subgradient algorithms for large-scale nonsmooth learning problems. *Mathematical Programming*. In Press.

Cui, W.-W., Lu, Z., Pan, E. (2014). Integrated production scheduling and maintenance policy for robustness in a single machine. *Computers and Operations Research*, 47, 81-91.

De Marco, G., Morgan, J. (2014). On Ordered Weighted Averaging Social Optima. *Journal of Optimization Theory and Applications*, 160 (2), 623-635.

de Moraes Bezerra, F., Melo, P., Costa, J.P. (2014). Visual and Interactive Comparative Analysis of Individual Opinions: A Group Decision Support Tool. *Group Decision and Negotiation*, 23 (1), 101-125.

- Dehnohalaji, A., Korhonen, P.J., Köksalan, M., Nasrabadi, N., Tezcaner Öztürk, D., Wallenius, J. (2014). Constructing a strict total order for alternatives characterized by multiple criteria: An extension. *Naval Research Logistics*, 61 (2), 155-163.
- Dell'Amico, M., Hadjicostantinou, E., Iori, M., Novellani, S. (2014). The bike sharing rebalancing problem: Mathematical formulations and benchmark instances. *Omega*, 45, 7-19.
- Demeyer, S., Goedgebeur, J., Audenaert, P., Pickavet, M., Demeester, P. (2013). Speeding up Martins' algorithm for multiple objective shortest path problems. *4OR*, 11 (4), 323-348.
- Deng, S., Aydin, R., Kwong, C.K., Huang, Y. (2014). Integrated product line design and supplier selection: A multi-objective optimization paradigm. *Computers & Industrial Engineering*, 70, 150-158.
- Derigs, U., Vogel, U. (2014). Experience with a framework for developing heuristics for solving rich vehicle routing problems. *Journal of Heuristics*, 20 (1), 75-106.
- Desrosiers, J., Gauthier, J.B., Lübbecke, M.E. (2014). Row-reduced column generation for degenerate master problems. *European Journal of Operational Research*, 236 (2), 453-460.
- Detienne, B. (2014). A mixed integer linear programming approach to minimize the number of late jobs with and without machine availability constraints. *European Journal of Operational Research*, 235 (3), 540-552.
- Devika, K., Jafarian, A., Hassanzadeh, A., Khodaverdi, R. (2014). Optimizing of bullwhip effect and net stock amplification in three-echelon supply chains using evolutionary multi-objective metaheuristics. *Annals of Operations Research*. In Press.
- Devika, K., Jafarian, A., Nourbakhsh, V. (2014). Designing a sustainable closed-loop supply chain network based on triple bottom line approach: A comparison of metaheuristics hybridization techniques. *European Journal of Operational Research*, 235 (3), 594-615.
- Di Corato, L., Montinari, N. (2014). Flexible waste management under uncertainty. *European Journal of Operational Research*, 234 (1), 174-185.
- Doan, N.A.V., Milojevic, D., Robert, F., De Smet, Y. (2014). A MOO-based methodology for designing 3d stacked integrated circuits. *Journal of Multi-Criteria Decision Analysis*, 21 (1-2), 43-63.
- Dobrzykowski, D., Saboori Deilami, V., Hong, P., Kim, S.-C. (2014). A structured analysis of operations and supply chain management research in healthcare (1982-2011). *International Journal of Production Economics*, 147 (B), 514-530.
- Dolgui, A., Kovalev, S., Kovalyov, M.Y., Nossack, J., Pesch, E. (2014). Minimizing setup costs in a transfer line design problem with sequential operation processing. *International Journal of Production Economics*, 151, 186-194.
- Dong, W., Chen, T., Tino, P., Yao, X. (2013). Scaling up estimation of distribution algorithms for continuous optimization. *IEEE Transaction on Evolutionary Computation*, 17 (6), 797-822.
- Dorsch, D., Jongen, H.T., Shikhman, V. (2013). On Intrinsic Complexity of Nash Equilibrium Problems and Bilevel Optimization. *Journal of Optimization Theory and Applications*, 159 (3), 606-634.
- Dorzán, M.G., Leguizamón, M.G., Mezura-Montes, E., Hernández-Peñalver, G. (2014). Approximated algorithms for the minimum dilation triangulation problem. *Journal of Heuristics*, 20 (2), 189-209.
- Dou, Y., Zhu, Q., Sarkis, J. (2014). Evaluating green supplier development programs with a grey-analytical network process-based methodology. *European Journal of Operational Research*, 233 (2), 420-431.
- Doumpos, M., Zopounidis, C., Galariotis, E. (2014). Inferring robust decision models in multicriteria classification problems: An experimental analysis. *European Journal of Operational Research*, 236 (2), 601-611.
- Dridi, O., Krichen, S., Guitouni, A. (2013). A multiobjective hybrid ant colony optimization approach applied to the assignment and scheduling problem. *International Transactions in Operational Research*. In Press.
- Druckman, D., Mitterhofer, R., Filzmoser, M., Koeszegi, S.T. (2014). Resolving Impasses in e-Negotiation: Does e-Mediation Work?. *Group Decision and Negotiation*, 23 (2), 193-210.
- Dubey, D., Mehra, A. (2014). A bipolar approach in fuzzy multi-objective linear programming. *Fuzzy Sets and Systems*. In Press.
- Dubois, D., Prade, H., Rico, A. (2014). The logical encoding of Sugeno integrals. *Fuzzy Sets and Systems*. In Press.
- Durea, M., Strugariu, R., Tammer, C. (2013). Scalarization in Geometric and Functional Vector Optimization Revisited. *Journal of Optimization Theory and Applications*, 159 (3), 635-655.

Edirisinghe, N.C.P., James, R.J.W. (2014). Fleet routing position-based model for inventory pickup under production shutdown. *European Journal of Operational Research*, 236 (2), 736-747.

Efremov, R.V., Lotov, A.V. (2014). Multi-criteria Remote Asynchronous Group Decision Screening: An Experimental Study. *Group Decision and Negotiation*, 23 (1), 31-48.

Eiselt, H.A., Marianov, V. (2014). A bi-objective model for the location of landfills for municipal solid waste. *European Journal of Operational Research*, 235 (1), 187-194.

Eiselt, H.A., Marianov, V. (2014). Multicriteria decision making under uncertainty: A visual approach. *International Transactions in Operational Research*. In Press.

El Hachemi, N., El Hallaoui, I., Gendreau, M., Rousseau, L.-M. (2014). Flow-based integer linear programs to solve the weekly log-truck scheduling problem. *Annals of Operations Research*. In Press.

Elizondo-Amaya, M.G., Ríos-Mercado, R.Z., Díaz, J.A. (2014). A dual bounding scheme for a territory design problem. *Computers and Operations Research*, 44, 193-205.

Elvikis, D., T'kindt, V. (2014). Two-agent scheduling on uniform parallel machines with min-max criteria. *Annals of Operations Research*, 213 (1), 79-94.

Emelichev, V., Korotkov, V., Nikulin, Y. (2014). Post-optimal analysis for markowitz's multicriteria portfolio optimization problem. *Journal of Multi-Criteria Decision Analysis*, 21 (1-2), 95-100.

Ensthaler, L., Giebe, T. (2014). Bayesian optimal knapsack procurement. *European Journal of Operational Research*, 234 (3), 597-609.

Eppe, S., De Smet, Y. (2014). Approximating Promethee II's net flow scores by piecewise linear value functions. *European Journal of Operational Research*, 233 (3), 651-659.

Esmaili, M., Shayanfar, H.A., Moslemi, R. (2014). Locating series FACTS devices for multi-objective congestion management improving voltage and transient stability. *European Journal of Operational Research*, 236 (2), 763-773.

Eusébio, A., Figueira, J.R., Ehrgott, M. (2014). On finding representative non-dominated points for bi-objective integer network flow problems. *Computers and Operations Research*, 48, 1-10.

Fakhri, A., Ghatee, M. (2013). Solution of preemptive multi-objective network design problems applying Benders decomposition method. *Annals of Operations Research*, 210 (1), 295-307.

Farahani, R.Z., Hekmatfar, M., Fahimnia, B., Kazemzadeh, N. (2014). Hierarchical facility location problem: Models, classifications, techniques, and applications. *Computers & Industrial Engineering*, 68, 104-117.

Farahani, R.Z., Rezapour, S., Drezner, T., Fallah, S. (2014). Competitive supply chain network design: An overview of classifications, models, solution techniques and applications. *Omega*, 45, 92-118.

Fasolo, B., Bana e Costa, C.A. (2014). Tailoring value elicitation to decision makers' numeracy and fluency: Expressing value judgments in numbers or words. *Omega*, 44, 83-90.

Feng, B., Lai, F. (2014). Multi-attribute group decision making with aspirations: A case study. *Omega*, 44, 136-147.

Fernandes, S., Captivo, M.E., Clímaco, J. (2014). A DSS for bicriteria location problems. *Decision Support Systems*, 57, 224-244.

Fernandez-Viagas, V., Framinan, J.M. (2014). On insertion tie-breaking rules in heuristics for the permutation flowshop scheduling problem. *Computers and Operations Research*, 45, 60-67.

Figielska, E. (2014). A heuristic for scheduling in a two-stage hybrid flowshop with renewable resources shared among the stages. *European Journal of Operational Research*, 236 (2), 433-444.

Firat, M., Hurkens, C.A.J., Laugier, A. (2014). Stable multi-skill workforce assignments. *Annals of Operations Research*, 213 (1), 95-114.

Fliege, J., Werner, R. (2014). Robust multiobjective optimization & applications in portfolio optimization. *European Journal of Operational Research*, 234 (2), 422-433.

Francis, R.A., Reyes-Jones, C. (2014). Decision-analytic approach for water sustainability definition: A higher education case study. *Journal of Multi-Criteria Decision Analysis*. In Press.

Fritzsche, R., Gupta, J.N.D., Lasch, R. (2014). Optimal prognostic distance to minimize total maintenance cost: The case of the airline industry. *International Journal of Production Economics*, 151, 76-88.

Fujimoto, T., Park, Y.W. (2014). Balancing supply chain competitiveness and robustness through "virtual dual

sourcing": Lessons from the Great East Japan Earthquake. *International Journal of Production Economics*, 147 (B), 429-436.

Gabrel, V., Murat, C., Thiele, A. (2014). Recent advances in robust optimization: An overview. *European Journal of Operational Research*, 235 (3), 471-483.

Gahm, C., Dünnwald, B., Sahamie, R. (2014). A multi-criteria master production scheduling approach for special purpose machinery. *International Journal of Production Economics*, 149, 89-101.

Gao, X., Zhong, W., Mei, S. (2013). Information security investment when hackers disseminate knowledge. *Decision Analysis*, 10 (4), 352-368.

Garcia-Piquer, A., Fornells, A., Bacardit, J., Orriols-Puig, A., Golobardes, E. (2014). Large-scale experimental evaluation of cluster representations for multiobjective evolutionary clustering. *IEEE Transaction on Evolutionary Computation*, 18 (1), 36-53.

Gartner, D., Kolisch, R. (2014). Scheduling the hospital-wide flow of elective patients. *European Journal of Operational Research*, 233 (3), 689-699.

Gaudioso, M., Giallombardo, G., Miglionico, G. (2013). Optimal Replenishment Order Placement in a Finite Time Horizon. *Journal of Optimization Theory and Applications*. In Press.

Gavalas, D., Konstantopoulos, C., Mastakas, K., Pantziou, G. (2014). A survey on algorithmic approaches for solving tourist trip design problems. *Journal of Heuristics*. In Press.

Gerstl, E., Mosheiov, G. (2013). Minmax due-date assignment with a time window for acceptable lead-times. *Annals of Operations Research*, 211 (1), 167-177.

Gerstl, E., Mosheiov, G. (2014). Single machine just-in-time scheduling problems with two competing agents. *Naval Research Logistics*, 61 (1), 1-16.

Gharehgozli, A.H., Yu, Y., De Koster, R., Udding, J.T. (2014). An exact method for scheduling a yard crane. *European Journal of Operational Research*, 235 (2), 431-447.

Gharis, L., Roise, J., McCarter, J. (2014). A compromise programming model for developing the cost of including carbon pools and flux into forest management. *Annals of Operations Research*. In Press.

Ghasemi, M.-R., Ignatius, J., Emrouznejad, A. (2014). A bi-objective weighted model for improving the discrimination power in MCDEA. *European Journal of Operational Research*, 233 (3), 640-650.

Ghiani, G., Laganà, D., Manni, E., Musmanno, R., Vigo, D. (2014). Operations research in solid waste management: A survey of strategic and tactical issues. *Computers and Operations Research*, 44, 22-32.

Ghiselli Ricci, R., Mesiar, R., Mesiarová-Zemánková, A. (2014). Lipschitz continuity of triangular subnorms. *Fuzzy Sets and Systems*, 240, 51-65.

Gomes, H.C., De Assis Das Neves, F., Souza, M.J.F. (2014). Multi-objective metaheuristic algorithms for the resource-constrained project scheduling problem with precedence relations. *Computers and Operations Research*, 44, 92-104.

Gomes, L.F.A.M., Machado, M.A.S., Rangel, L.A.D. (2013). Behavioral multi-criteria decision analysis: The TODIM method with criteria interactions. *Annals of Operations Research*, 211 (1), 531-548.

Gong, J., Mitchell, J.E., Krishnamurthy, A., Wallace, W.A. (2014). An interdependent layered network model for a resilient supply chain. *Omega*, 46, 104-116.

Gong, M., Cai, Q., Chen, X., Ma, L. (2014). Complex network clustering by multiobjective discrete particle swarm optimization based on decomposition. *IEEE Transaction on Evolutionary Computation*, 18 (1), 82-97.

González-Pachón, J., Diaz-Balteiro, L., Romero, C. (2014). How to combine inconsistent ordinal and cardinal preferences: A satisficing modelling approach. *Computers & Industrial Engineering*, 67, 168-172.

Gourion, D., Luc, D.T. (2014). Saddle points and scalarizing sets in multiple objective linear programming. *Mathematical Methods of Operations Research*. In Press.

Govindan, K., Jafarian, A., Khodaverdi, R., Devika, K. (2014). Two-echelon multiple-vehicle location-routing problem with time windows for optimization of sustainable supply chain network of perishable food. *International Journal of Production Economics*. In Press.

Govindan, K., Kaliyan, M., Kannan, D., Haq, A.N. (2014). Barriers analysis for green supply chain management implementation in Indian industries using analytic hierarchy process. *International Journal of Production Economics*, 147 (B), 555-568.

Govindan, K., Sarkis, J., Jabbour, C.J.C., Zhu, Q., Geng, Y. (2014). Eco-efficiency based green supply chain management: Current status and opportunities. *European Journal of Operational Research*, 233 (2), 293-298.

Grandoni, F., Ravi, R., Singh, M., Zenklusen, R. (2013). New approaches to multi-objective optimization. *Mathematical Programming*. In Press.

Greco, S., Mesiar, R., Rindone, F. (2014). Discrete bipolar universal integrals. *Fuzzy Sets and Systems*. In Press.

Greco, S., Rindone, F. (2013). The bipolar Choquet integral representation. *Theory and Decision*. In Press.

Green Jr., K.W., Inman, R.A., Birou, L.M., Whitten, D. (2014). Total JIT (T-JIT) and its impact on supply chain competency and organizational performance. *International Journal of Production Economics*, 147 (A), 125-135.

Güden, H., Süral, H. (2014). Locating mobile facilities in railway construction management. *Omega*, 45, 71-79.

Gunasekaran, A., Hong, P., Fujimoto, T. (2014). Building supply chain system capabilities in the age of global complexity: Emerging theories and practices. *International Journal of Production Economics*, 147 (B), 189-197.

Guo, C., Li, X. (2014). A multi-echelon inventory system with supplier selection and order allocation under stochastic demand. *International Journal of Production Economics*, 151, 37-47.

Guo, P., Li, Y. (2014). Approaches to multistage one-shot decision making. *European Journal of Operational Research*, 236 (2), 612-623.

Gustavsson, E., Patriksson, M., Strömberg, A.-B., Wojciechowski, A., Önnheim, M. (2014). Preventive maintenance scheduling of multi-component systems with interval costs. *Computers & Industrial Engineering*. In Press.

Gutjahr, W.J., Pichler, A. (2013). Stochastic multi-objective optimization: a survey on non-scalarizing methods. *Annals of Operations Research*. In Press.

Haddou, H.A., Camilleri, G., Zaraté, P. (2014). Prediction of Ideas Number During a Brainstorming Session. *Group Decision and Negotiation*, 23 (2), 271-298.

Halme, M., Somervuori, O. (2013). Choice behavior of information services when prices are increased and decreased from reference level. *Annals of Operations Research*, 211 (1), 549-564.

Han, S.Y., Bae, S.J. (2014). Internalization of R&D outsourcing: An empirical study. *International Journal of Production Economics*, 150, 58-73.

Hanafí, R., Kozan, E. (2014). A hybrid constructive heuristic and simulated annealing for railway crew scheduling. *Computers & Industrial Engineering*, 70, 11-19.

Hatami-Marbini, A., Tavana, M., Gholami, K., Beigi, Z.G. (2014). A Bounded Data Envelopment Analysis Model in a Fuzzy Environment with an Application to Safety in the Semiconductor Industry. *Journal of Optimization Theory and Applications*. In Press.

Hazir, Ö., Kedad-Sidhoum, S. (2014). Batch sizing and just-in-time scheduling with common due date. *Annals of Operations Research*, 213 (1), 187-202.

He, Z., Wang, N., Li, P. (2014). Simulated annealing for financing cost distribution based project payment scheduling from a joint perspective. *Annals of Operations Research*, 213 (1), 203-220.

Heitmann, H., Brüggemann, W. (2013). Preference-based assignment of university students to multiple teaching groups. *OR Spectrum*, In Press.

Hemmecke, R., Köppe, M., Weismantel, R. (2013). Graver basis and proximity techniques for block-structured separable convex integer minimization problems. *Mathematical Programming*. In Press.

Hernández, J.E., Mula, J., Poler, R., Lyons, A.C. (2014). Collaborative Planning in Multi-tier Supply Chains Supported by a Negotiation-Based Mechanism and Multi-agent System. *Group Decision and Negotiation*, 23 (2), 235-269.

Ho, W.-T., Lai, S.-F., Huang, Y.-K. (2014). An Optimal Mixed Batch Shipment Policy for Multiple Items in a Single-Supplier Multiple-Retailer Integrated System. *Journal of Optimization Theory and Applications*, 160 (2), 636-658.

Hong, Y., Visich, J.K., Pinto, P.A., Khumawala, B.M. (2013). Evaluation of mixed-model U-line operational designs. *International Transactions in Operational Research*. In Press.

Houssin, R., Coulibaly, A. (2014). Safety-based availability assessment at design stage. *Computers & Industrial Engineering*, 70, 107-115.

Hsu, T.-H., Lin, L.-Z. (2014). Using Fuzzy Preference Method for Group Package Tour Based on the Risk Perception. *Group Decision and Negotiation*, 23 (2), 299-323.

Hsueh, C.-F. (2014). Improving corporate social responsibility in a supply chain through a new revenue sharing contract. *International Journal of Production Economics*, 151, 214-222.

Hu, B.Q., Wang, C.Y. (2014). On type-2 fuzzy relations and interval-valued type-2 fuzzy sets. *Fuzzy Sets and Systems*, 236, 1-32.

- Hu, N., Koh, N.S., Reddy, S.K. (2014). Ratings lead you to the product, reviews help you clinch it? the mediating role of online review sentiments on product sales. *Decision Support Systems*, 57, 42-53.
- Hu, Q.-M., Hu, Z.-H., Du, Y. (2014). Berth and quay-crane allocation problem considering fuel consumption and emissions from vessels. *Computers & Industrial Engineering*, 70, 1-10.
- Hu, X., Motwani, J.G. (2014). Minimizing downside risks for global sourcing under price-sensitive stochastic demand, exchange rate uncertainties, and supplier capacity constraints. *International Journal of Production Economics*, 147 (B), 398-409.
- Huang, Y., Li, Z., Guo, X. (2014). Constrained optimality for finite horizon semi-Markov decision processes in Polish spaces. *Operations Research Letters*, 42 (2), 123-129.
- Huh, W.T., Rusmevichientong, P. (2014). Online sequential optimization with biased gradients: Theory and applications to censored demand. *INFORMS Journal on Computing*, 26 (1), 150-159.
- Humeau, J., Liefoghe, A., Talbi, E.-G., Verel, S. (2013). ParadisEO-MO: From fitness landscape analysis to efficient local search algorithms. *Journal of Heuristics*, 19 (6), 881-915.
- Hyde, M.R., Burke, E.K., Kendall, G. (2013). Automated code generation by local search. *Journal of the Operational Research Society*, 64 (12), 1725-1741.
- Iancu, D.A., Trichakis, N. (2014). Pareto efficiency in robust optimization. *Management Science*, 60 (1), 130-147.
- Ighravwe, D.E., Oke, S.A. (2014). A non-zero integer non-linear programming model for maintenance workforce sizing. *International Journal of Production Economics*, 150, 204-214.
- Israeli, A.A., Brown, J.R. (2014). An approach for determining the mix between human and automated service providers. *Journal of Multi-Criteria Decision Analysis*. In Press.
- Ivanov, D., Pavlov, A., Sokolov, B. (2014). Optimal distribution (re)planning in a centralized multi-stage supply network under conditions of the ripple effect and structure dynamics. *European Journal of Operational Research*. In Press.
- Jadidi, O., Zolfaghari, S., Cavalieri, S. (2014). A new normalized goal programming model for multi-objective problems: A case of supplier selection and order allocation. *International Journal of Production Economics*, 148, 158-165.
- Jana, M., Panda, G. (2014). Solution of nonlinear interval vector optimization problem. *Operational Research*, 14 (1), 71-85.
- Jayaram, J., Dixit, M., Motwani, J. (2014). Supply chain management capability of small and medium sized family businesses in India: A multiple case study approach. *International Journal of Production Economics*, 147 (B), 472-485.
- Jeong, B., Kim, Y.-D. (2014). Minimizing total tardiness in a two-machine re-entrant flowshop with sequence-dependent setup times. *Computers and Operations Research*, 72-80.
- Jia, S., Hu, Z.-H. (2014). Path-relinking Tabu search for the multi-objective flexible job shop scheduling problem. *Computers and Operations Research*, 47, 11-26.
- Jia, Z.-H., Leung, J.Y.-T. (2014). An improved meta-heuristic for makespan minimization of a single batch machine with non-identical job sizes. *Computers and Operations Research*, 46, 49-58.
- Jiang, Y., Deng, S. (2013). Enhanced Efficiency in Multi-objective Optimization. *Journal of Optimization Theory and Applications*. In Press.
- Judt, L., Mersmann, O., Naujoks, B. (2013). Non-monotonicity of observed hypervolume in 1-Greedy S-metric selection. *Journal of Multi-Criteria Decision Analysis*, 20 (5-6), 277-290.
- Kadziński, M., Corrente, S., Greco, S., Słowiński, R. (2014). Preferential reducts and constructs in robust multiple criteria ranking and sorting. *OR Spectrum*, In Press.
- Kalashnikov, V.V., Bulavsky, V.A., Kalashnikov Jr., V.V., Kalashnykova, N.I. (2014). Structure of demand and consistent conjectural variations equilibrium (CCVE) in a mixed oligopoly model. *Annals of Operations Research*. In Press.
- Kalcsics, J., Nickel, S., Pozo, M.A., Puerto, J., Rodríguez-Chía, A.M. (2014). The multicriteria p-facility median location problem on networks. *European Journal of Operational Research*, 235 (3), 484-493.
- Kangasputna, J., Salo, A. (2014). Expert judgments in the cost-effectiveness analysis of resource allocations: A case study in military planning. *OR Spectrum*, 36 (1), 161-185.
- Kannan, D., De Sousa Jabbour, A.B.L., Jabbour, C.J.C. (2014). Selecting green suppliers based on GSCM practices: Using Fuzzy TOPSIS applied to a Brazilian electronics company. *European Journal of Operational Research*, 233 (2), 432-447.

Kao, C. (2014). Efficiency decomposition in network data envelopment analysis with slacks-based measures. *Omega*, 45, 1-6.

Karaarslan, A.G., Kiesmüller, G.P., de Kok, A.G. (2013). Effect of modeling fixed cost in a serial inventory system with periodic review. *OR Spectrum*, In Press.

Karhi, S., Shabtay, D. (2014). Online scheduling of two job types on a set of multipurpose machines. *International Journal of Production Economics*, 150, 155-162.

Karimi, N., Davoudpour, H. (2014). A high performing metaheuristic for multi-objective flowshop scheduling problem. *Computers and Operations Research*. In Press.

Karmakar, S., Bhunia, A.K. (2014). Uncertain constrained optimization by interval-oriented algorithm. *Journal of the Operational Research Society*, 65 (1), 73-87.

Karsu, T., Morton, A. (2014). Incorporating balance concerns in resource allocation decisions: A bi-criteria modelling approach. *Omega*, 44, 70-82.

Katsikopoulos, K.V. (2013). Why do simple heuristics perform well in choices with binary attributes? *Decision Analysis*, 10 (4), 327-340.

Keller, P.W., Levi, R., Perakis, G. (2013). Efficient formulations for pricing under attraction demand models. *Mathematical Programming*. In Press.

Khowala, K., Fowler, J., Keha, A., Balasubramanian, H. (2014). Single machine scheduling with interfering job sets. *Computers and Operations Research*, 45, 97-107.

Kiassat, C., Safaei, N., Banjevic, D. (2014). Choosing the optimal intervention method to reduce human-related machine failures. *European Journal of Operational Research*, 233 (3), 604-612.

Kim, K.-K.K., Hovakimyan, N. (2013). Multi-Criteria Optimization for Filter Design of L1 Adaptive Control. *Journal of Optimization Theory and Applications*. In Press.

Kitchen, B., Carmona, C., Warburton, P., Mazonowicz, R. (2013). Practice summary: Decision conferencing rationalises defence training. *Interfaces*, 43 (6), 550-553.

Klibi, W., Martel, A. (2013). The design of robust value-creating supply chain networks. *OR Spectrum*, 35 (4), 867-903.

Knight, L., Tu, Y.-H., Preston, J. (2014). Integrating skills profiling and purchasing portfolio management: An opportunity for building purchasing capability. *International Journal of Production Economics*, 147 (B), 271-283.

Köbis, E. (2013). On Robust Optimization - Relations Between Scalar Robust Optimization and Unconstrained Multicriteria Optimization. *Journal of Optimization Theory and Applications*. In Press.

Kodaganallur, V., Sen, A.K., Mitra, S. (2014). Application of graph search and genetic algorithms for the single machine scheduling problem with sequence-dependent setup times and quadratic penalty function of completion times. *Computers & Industrial Engineering*, 67, 10-19.

Kolesárová, A., Mesiar, R., Rückschlossová, T. (2014). Power stable aggregation functions. *Fuzzy Sets and Systems*, 240, 39-50.

Korhonen, P.J., Silvennoinen, K., Wallenius, J., Öörni, A. (2013). A careful look at the importance of criteria and weights. *Annals of Operations Research*, 211 (1), 565-578.

Kothiyal, A., Spinu, V., Wakker, P.P. (2014). Average utility maximization: A preference foundation. *Operations Research*, 62 (1), 207-218.

Kotiadis, K., Tako, A.A., Vasilakis, C. (2014). A participative and facilitative conceptual modelling framework for discrete event simulation studies in healthcare. *Journal of the Operational Research Society*, 65 (2), 197-213.

Kou, G., Lin, C. (2014). A cosine maximization method for the priority vector derivation in AHP. *European Journal of Operational Research*, 235 (1), 225-232.

Koufteros, X., Droge, C., Heim, G., Massad, N., Vickery, S.K. (2014). Encounter Satisfaction in E-tailing: Are the relationships of order fulfillment service quality with its antecedents and consequences moderated by historical satisfaction? *Decision Sciences*, 45(1), 5-48.

Kovalyov, M.Y., Pesch, E. (2014). A game mechanism for single machine sequencing with zero risk. *Omega*, 44, 104-110.

Kozanidis, G., Gavranis, A., Liberopoulos, G. (2013). Heuristics for flight and maintenance planning of mission aircraft. *Annals of Operations Research*. In Press.

Kumar, D., Singh, J., Singh, O.P., Seema (2013). A fuzzy logic based decision support system for evaluation of suppliers in supply chain management practices. *Mathematical and Computer Modelling*, 58 (11-12), 1679-1695.

Ladier, A.-L., Alpan, G., Penz, B. (2014). Joint employee weekly timetabling and daily rostering: A decision-support tool for a logistics platform. *European Journal of Operational Research*, 234 (1), 278-291.

Laha, D., Sapkal, S.U. (2014). An improved heuristic to minimize total flow time for scheduling in the m-machine

no-wait flow shop. *Computers & Industrial Engineering*, 67, 36-43.

Lalmazloumian, M., Wong, K.Y., Govindan, K., Kannan, D. (2013). A robust optimization model for agile and build-to-order supply chain planning under uncertainties. *Annals of Operations Research*. In Press.

Lau, K.H. (2013). Measuring distribution efficiency of a retail network through data envelopment analysis. *International Journal of Production Economics*, 146 (2), 598-611.

Lau, N., Hasija, S., Bearden, J.N. (2014). Newsvendor pull-to-center reconsidered. *Decision Support Systems*, 58, 68-73.

Lazimy, R. (2013). Interactive Polyhedral Outer Approximation (IPOA) strategy for general multiobjective optimization problems. *Annals of Operations Research*, 210 (1), 73-99.

Lee, C.-C. (2014). Development and evaluation of the many-to-many supplier negotiation strategy. *Computers & Industrial Engineering*, 70, 90-97.

Lee, C.-H., Liao, C.-J., Chung, T.-P. (2014). Scheduling with multi-attribute setup times on two identical parallel machines. *International Journal of Production Economics*. In Press.

Lee, K.-B., Kim, J.-H. (2013). Multiobjective particle swarm optimization with preference-based sort and its application to path following footstep optimization for humanoid robots. *IEEE Transaction on Evolutionary Computation*, 17 (6), 755-766.

Lee, S., Kim, D. (2014). An optimal policy for a single-vendor single-buyer integrated production-distribution model with both deteriorating and defective items. *International Journal of Production Economics*, 147 (A), 161-170.

Lei, Y., Gong, M., Zhang, J., Li, W., Jiao, L. (2014). Resource allocation model and double-sphere crowding distance for evolutionary multi-objective optimization. *European Journal of Operational Research*, 234 (1), 197-208.

Levitin, G., Xing, L., Dai, Y. (2014). Cold vs. hot standby mission operation cost minimization for 1-out-of-N systems. *European Journal of Operational Research*, 234 (1), 155-162.

Li, C., Liu, S. (2014). Random network models and sensitivity algorithms for the analysis of ordering time and inventory state in multi-stage supply chains. *Computers & Industrial Engineering*, 70, 168-175.

Li, J., Sun, X., Wang, F., Wu, D. (2014). Risk integration and optimization of oil-importing maritime system: a multi-objective programming approach. *Annals of Operations Research*. In Press.

Li, K., Fialho, A., Kwong, S., Zhang, Q. (2014). Adaptive operator selection with bandits for a multiobjective evolutionary algorithm based on decomposition. *IEEE Transaction on Evolutionary Computation*, 18 (1), 114-130.

Li, X., Natarajan, K., Teo, C.-P., Zheng, Z. (2014). Distributionally robust mixed integer linear programs: Persistency models with applications. *European Journal of Operational Research*, 233 (3), 459-473.

Li, Y. (2014). The impact of disposition to privacy, website reputation and website familiarity on information privacy concerns. *Decision Support Systems*, 57, 343-354.

Li, Y., Qin, K., He, X. (2014). Some new approaches to constructing similarity measures. *Fuzzy Sets and Systems*, 234, 46-60.

Li, Z.-T., Chen, Q.-X., Mao, N., Wang, X., Liu, J. (2013). Scheduling rules for two-stage flexible flow shop scheduling problem subject to tail group constraint. *International Journal of Production Economics*, 146 (2), 667-678.

Liang, Z., Lee, C., Chaovalitwongse, W.A. (2013). Mathematical programming approaches for dual multicast routing problem with multilayer risk cost. *Annals of Operations Research*. In Press.

Liao, C.-N., Kao, H.-P. (2014). An evaluation approach to logistics service using fuzzy theory, quality function development and goal programming. *Computers & Industrial Engineering*, 68, 54-64.

Liao, T., Stützle, T., Montes De Oca, M.A., Dorigo, M. (2014). A unified ant colony optimization algorithm for continuous optimization. *European Journal of Operational Research*, 234 (3), 597-609.

Liesiö, J., Punkka, A. (2014). Baseline value specification and sensitivity analysis in multiattribute project portfolio selection. *European Journal of Operational Research*. In Press.

Lin, C., Kou, G., Ergu, D. (2013). An improved statistical approach for consistency test in AHP. *Annals of Operations Research*, 211 (1), 289-299.

Lin, J.T., Chen, T.-L., Chu, H.-C. (2014). A stochastic dynamic programming approach for multi-site capacity planning in TFT-LCD manufacturing under demand uncertainty. *International Journal of Production Economics*, 148, 21-36.

- Lin, Y., Hu, X., Li, X., Wu, X. (2013). Mining stable patterns in multiple correlated databases. *Decision Support Systems*, 56, 202-210.
- Liu, B., Zhang, Q., Fernandez, F.V., Gielen, G.G.E. (2013). An efficient evolutionary algorithm for chance-constrained bi-objective stochastic optimization. *IEEE Transaction on Evolutionary Computation*, 17 (6), 786-796.
- Liu, F., Zhang, W.-G., Zhang, L.-H. (2014). Consistency analysis of triangular fuzzy reciprocal preference relations. *European Journal of Operational Research*, 235 (3), 718-726.
- Ljubić, I., Putz, P., Salazar-González, J.-J. (2014). A MIP-based approach to solve the prize-collecting local access network design problem. *European Journal of Operational Research*, 235 (3), 727-739.
- Locatelli, M., Schoen, F. (2013). Global optimization based on local searches. *4OR*, 11 (4), 301-321.
- Lokman, B., Köksalan, M., Korhonen, P.J., Wallenius, J. (2014). An interactive algorithm to find the most preferred solution of multi-objective integer programs. *Annals of Operations Research*. In Press.
- Lopes, R.B., Ferreira, C., Santos, B.S., Barreto, S. (2013). A taxonomical analysis, current methods and objectives on location-routing problems. *International Transactions in Operational Research*. In Press.
- López-Ibáñez, M., Stützle, T. (2014). Automatically improving the anytime behaviour of optimisation algorithms. *European Journal of Operational Research*, 235 (3), 569-582.
- Lotfi, M.M., Ghaderi, S.F. (2014). A compromised multi-objective solution using fuzzy mixed integer goal programming for market-based short-term unit commitment problem. *Journal of the Operational Research Society*, 65 (1), 23-36.
- Lu, M.-T., Lin, S.-W., Tzeng, G.-H. (2013). Improving RFID adoption in Taiwan's healthcare industry based on a DEMATEL technique with a hybrid MCDM model. *Decision Support Systems*, 56, 259-269.
- Luo, H., Du, B., Huang, G.Q., Chen, H., Li, X. (2013). Hybrid flow shop scheduling considering machine electricity consumption cost. *International Journal of Production Economics*, 146 (2), 423-439.
- Luo, Z., Qin, H., Lim, A. (2014). Branch-and-price-and-cut for the multiple traveling repairman problem with distance constraints. *European Journal of Operational Research*, 234 (1), 49-60.
- Lust, T., Tuytens, D. (2014). Variable and large neighborhood search to solve the multiobjective set covering problem. *Journal of Heuristics*, 20 (2), 165-188.
- Madani, K., Sheikhmohammady, M., Mokhtari, S., Moradi, M., Xanthopoulos, P. (2013). Social Planner's Solution for the Caspian Sea Conflict. *Group Decision and Negotiation*. In Press.
- Mahlberg, B., Luptacik, M. (2014). Eco-efficiency and eco-productivity change over time in a multisectoral economic system. *European Journal of Operational Research*, 234 (3), 885-897.
- Mailly, D., Abi-Zeid, I., Pepin, S. (2014). A multi-criteria classification approach for identifying favourable climates for tourism. *Journal of Multi-Criteria Decision Analysis*, 21 (1-2), 65-75.
- Makarouni, I., Psarras, J., Siskos, E. (2013). Interactive bicriterion decision support for a large scale industrial scheduling system. *Annals of Operations Research*. In Press.
- Mallor, F., Guardiola, I.G. (2014). The Weibull scheduling index for client driven manufacturing processes. *International Journal of Production Economics*, 150, 225-238.
- Mansini, R., Ogryczak, W., Speranza, M.G. (2014). Twenty years of linear programming based portfolio optimization. *European Journal of Operational Research*, 234 (2), 518-535.
- Mansour, K., Kowalczyk, R. (2014). An Approach to One-to-Many Concurrent Negotiation. *Group Decision and Negotiation*. In Press.
- Marsillac, E., Roh, J.J. (2014). Connecting product design, process and supply chain decisions to strengthen global supply chain capabilities. *International Journal of Production Economics*, 147 (B), 317-329.
- Martin, D., Rosete, A., Alcalá-Fdez, J., Herrera, F. (2014). A new multiobjective evolutionary algorithm for mining a reduced set of interesting positive and negative quantitative association rules. *IEEE Transaction on Evolutionary Computation*, 18 (1), 54-69.
- Martínez-Salazar, I.A., Molina, J., Ángel-Bello, F., Gómez, T., Caballero, R. (2014). Solving a bi-objective transportation location routing problem by metaheuristic algorithms. *European Journal of Operational Research*, 234 (1), 25-36.
- Martins, M.D.B., Xavier, A., Fragoso, R. (2014). A bioeconomic forest management model for the mediterranean forests: A multicriteria approach. *Journal of Multi-Criteria Decision Analysis*, 21 (1-2), 101-111.

Mason, J.E., Denton, B.T., Shah, N.D., Smith, S.A. (2014). Optimizing the simultaneous management of blood pressure and cholesterol for type 2 diabetes patients. *European Journal of Operational Research*, 233 (3), 727-738.

Mattila, V., Virtanen, K., Hämäläinen, R.P. (2013). A simulated annealing algorithm for noisy multiobjective optimization. *Journal of Multi-Criteria Decision Analysis*, 20 (5-6), 255-276.

Mattiussi, A., Rosano, M., Simeoni, P. (2014). A decision support system for sustainable energy supply combining multi-objective and multi-attribute analysis: An Australian case study. *Decision Support Systems*, 57, 150-159.

Mayorga, M.E., Ahn, H.-S., Aydin, G. (2013). Assortment and inventory decisions with multiple quality levels. *Annals of Operations Research*, 211 (1), 301-331.

Medal, H.R., Pohl, E.A., Rossetti, M.D. (2014). A multi-objective integrated facility location-hardening model: Analyzing the pre- and post-disruption tradeoff. *European Journal of Operational Research*. In Press.

Mehta, V.K., Dasgupta, B. (2014). Parametric approximation of the pareto set in multi-objective optimization problems. *Journal of Multi-Criteria Decision Analysis*. In Press.

Melouk, S.H., Fontem, B.A., Waymire, E., Hall, S. (2014). Stochastic resource allocation using a predictor-based heuristic for optimization via simulation. *Computers and Operations Research*, 46, 38-48.

Meng, F., Zhang, Q. (2014). Induced continuous Choquet integral operators and their application to group decision making. *Computers & Industrial Engineering*, 68, 42-53.

Merigó, J.M., Casanovas, M., Yang, J.-B. (2014). Group decision making with expertons and uncertain generalized probabilistic weighted aggregation operators. *European Journal of Operational Research*, 235 (1), 215-224.

Mielczarek, B. (2014). Simulation modelling for contracting hospital emergency services at the regional level. *European Journal of Operational Research*, 235 (1), 287-299.

Miettinen, K. (2014). Survey of methods to visualize alternatives in multiple criteria decision making problems. *OR Spectrum*, 36 (1), 3-37.

Miettinen, K., Mustajoki, J., Stewart, T.J. (2014). Interactive multiobjective optimization with NIMBUS for decision making under uncertainty. *OR Spectrum*, 36 (1), 39-56.

Millstein, M.A., Yang, L., Li, H. (2014). Optimizing ABC inventory grouping decisions. *International Journal of Production Economics*, 148, 71-80.

Mishra, S.K., Panda, G., Majhi, R. (2014). Constrained portfolio asset selection using multiobjective bacteria foraging optimization. *Operational Research*, 14 (1), 113-145.

Mishra, S.K., Upadhyay, B.B., An, L.T.H. (2014). Lagrange Multiplier Characterizations of Solution Sets of Constrained Nonsmooth Pseudolinear Optimization Problems. *Journal of Optimization Theory and Applications*, 160 (3), 763-777.

Mistry, J., Sarkis, J., Dhavale, D.G. (2014). Multi-criteria analysis using latent class cluster ranking: An investigation into corporate resiliency. *International Journal of Production Economics*, 148, 1-13.

Moghaddam, K.S. (2013). Multi-objective preventive maintenance and replacement scheduling in a manufacturing system using goal programming. *International Journal of Production Economics*, 146 (2), 704-716.

Montes, I., Miranda, E., Montes, S. (2014). Decision making with imprecise probabilities and utilities by means of statistical preference and stochastic dominance. *European Journal of Operational Research*, 234 (1), 209-220.

Mor, B., Mosheiov, G. (2014). Polynomial time solutions for scheduling problems on a proportionate flowshop with two competing agents. *Journal of the Operational Research Society*, 65 (1), 151-157.

Mukhopadhyay, A., Maulik, U., Bandyopadhyay, S., Coello, C.A.C. (2014). A survey of multiobjective evolutionary algorithms for data mining: Part I. *IEEE Transaction on Evolutionary Computation*, 18 (1), 4-19.

Mukhopadhyay, A., Maulik, U., Bandyopadhyay, S., Coello, C.A.C. (2014). Survey of multiobjective evolutionary algorithms for data mining: Part II. *IEEE Transaction on Evolutionary Computation*, 18 (1), 25-35.

Nair, R., Miller-Hooks, E. (2014). Equilibrium network design of shared-vehicle systems. *European Journal of Operational Research*, 235 (1), 47-61.

Navaei, J., Fatemi Ghomi, S.M.T., Jolai, F., Mozdgir, A. (2014). Heuristics for an assembly flow-shop with non-identical assembly machines and sequence dependent setup times to minimize sum of holding and delay costs. *Computers and Operations Research*, 44, 52-65.

Neto, T., Constantino, M., Martins, I., Pedroso, J.P. (2013). A branch-and-bound procedure for forest harvest

scheduling problems addressing aspects of habitat availability. *International Transactions in Operational Research*. In Press.

Niaki, S.T.A., Khedmati, M. (2014). Change point estimation of high-yield processes experiencing monotonic disturbances. *Computers & Industrial Engineering*, 67, 82-92.

Nolz, P.C., Absi, N., Feillet, D. (2014). A bi-objective inventory routing problem for sustainable waste management under uncertainty. *Journal of Multi-Criteria Decision Analysis*. In Press.

Norese, M.F., Carbone, V. (2014). An application of ELECTRE tri to support innovation. *Journal of Multi-Criteria Decision Analysis*, 21 (1-2), 77-93.

Nouri Shirazi, M.R., Mollamahmoudi, H., Seyedpoor, S.M. (2014). Structural Damage Identification Using an Adaptive Multi-stage Optimization Method Based on a Modified Particle Swarm Algorithm. *Journal of Optimization Theory and Applications*, 160 (3), 1009-1019.

Novak, D.C., Sullivan, J.L. (2014). A link-focused methodology for evaluating accessibility to emergency services. *Decision Support Systems*, 57, 309-319.

Ondemir, O., Gupta, S.M. (2014). A multi-criteria decision making model for advanced repair-to-order and disassembly-to-order system. *European Journal of Operational Research*, 233 (2), 408-419.

Örmeci, E.L., Salman, F.S., Yücel, E. (2014). Staff rostering in call centers providing employee transportation. *Omega*, 43, 41-53.

Ormerod, R.J. (2014). Critical rationalism in practice: Strategies to manage subjectivity in or investigations. *European Journal of Operational Research*, 235 (3), 784-797.

Oron, D. (2014). Scheduling controllable processing time jobs in a deteriorating environment. *Journal of the Operational Research Society*, 65 (1), 49-56.

Östermark, R. (2014). A parallel fuzzy GMM-algorithm for approximate VGARCH-modeling with a multi-modal discontinuous merit function. *Fuzzy Sets and Systems*. In Press.

Otto, A., Otto, C. (2014). How to design effective priority rules: Example of simple assembly line balancing. *Computers & Industrial Engineering*, 69, 43-52.

Otto, C., Otto, A. (2014). Multiple-source learning precedence graph concept for the automotive industry. *European Journal of Operational Research*, 234 (1), 253-265.

Ozlen, M., Burton, B.A., MacRae, C.A.G. (2014). Multi-Objective Integer Programming: An Improved Recursive Algorithm. *Journal of Optimization Theory and Applications*, 160 (2), 470-482.

Padmanabhan, D. (2013). A clustering-based methodology for discontinuous pareto frontier representation. *Journal of Multi-Criteria Decision Analysis*, 20 (5-6), 235-253.

Palmeira, E.S., Bedregal, B.R.C., Fernandez, J., Jurio, A. (2014). On the extension of lattice-valued implications via retractions. *Fuzzy Sets and Systems*, 240, 66-85.

Pan, Q.-K., Ruiz, R. (2014). An effective iterated greedy algorithm for the mixed no-idle permutation flowshop scheduling problem. *Omega*, 44, 41-50.

Pan, Q.-K., Wang, L., Li, J.-Q., Duan, J.-H. (2014). A novel discrete artificial bee colony algorithm for the hybrid flowshop scheduling problem with makespan minimisation. *Omega*, 45, 42-56.

Pan, T., Zhang, Z.-H., Cao, H. (2014). Collaborative production planning with production time windows and order splitting in make-to-order manufacturing. *Computers & Industrial Engineering*, 67, 1-9.

Pan, W., Yu, L., Wang, S., Wang, X. (2014). A fuzzy multi-objective model for provider selection in data communication services with different QoS levels. *International Journal of Production Economics*, 147 (C), 689-696.

Panagiotidou, S. (2014). Joint optimization of spare parts ordering and maintenance policies for multiple identical items subject to silent failures. *European Journal of Operational Research*, 235 (1), 300-314.

Patriota, A.G. (2014). A classical measure of evidence for general null hypotheses. *Fuzzy Sets and Systems*, 233, 74-88.

Pendharkar, P.C., Troutt, M.D. (2014). Interactive classification using data envelopment analysis. *Annals of Operations Research*, 214 (1), 125-141.

Pereira-Fariña, M., Vidal, J.C., Díaz-Hermida, F., Bugarín, A. (2014). A fuzzy syllogistic reasoning schema for generalized quantifiers. *Fuzzy Sets and Systems*, 234, 79-96.

Perez, F., Gomez, T. (2014). Multiobjective project portfolio selection with fuzzy constraints. *Annals of Operations Research*. In Press.

Perez-Gonzalez, P., Framinan, J.M. (2014). A common framework and taxonomy for multicriteria scheduling problems with interfering and competing jobs: Multi-agent

scheduling problems. *European Journal of Operational Research*, 235 (1), 1-16.

Pham, L., Zaitsev, A., Steiner, R., Teich, J.E. (2013). *NegotiAuction: An experimental study*. *Decision Support Systems*, 56, 300-309.

Pinheiro De Lima, E., Gouvea Da Costa, S.E., Angelis, J.J., Munik, J. (2013). Performance measurement systems: A consensual analysis of their roles. *International Journal of Production Economics*, 146 (2), 524-542.

Prats, F., Roselló, L., Sánchez, M., Agell, N. (2014). Using L-fuzzy sets to introduce information theory into qualitative reasoning. *Fuzzy Sets and Systems*, 236, 73-90.

Prodhon, C., Prins, C. (2014). A survey of recent research on location-routing problems. *European Journal of Operational Research*. In Press.

Puranam, K.S., Katehakis, M.N. (2014). On optimal bidding and inventory control in sequential procurement auctions: the multi period case. *Annals of Operations Research*. In Press.

Qian, L. (2014). Market-based supplier selection with price, delivery time, and service level dependent demand. *International Journal of Production Economics*, 147 (C), 697-706.

Qin, F., Baczyński, M. (2014). Distributivity equations of implications based on continuous triangular conorms (II). *Fuzzy Sets and Systems*, 240, 86-102.

Qrunfleh, S., Tarafdar, M. (2014). Supply chain information systems strategy: Impacts on supply chain performance and firm performance. *International Journal of Production Economics*, 147 (B), 340-350.

Qu, S., Liu, C., Goh, M., Li, Y., Ji, Y. (2014). Nonsmooth multiobjective programming with quasi-Newton methods. *European Journal of Operational Research*, 235 (3), 503-510.

Qu, S.-J., Goh, M., De Souza, R., Wang, T.-N. (2014). Proximal Point Algorithms for Convex Multi-criteria Optimization with Applications to Supply Chain Risk Management. *Journal of Optimization Theory and Applications*. In Press.

Rachuba, S., Werners, B. (2014). A robust approach for scheduling in hospitals using multiple objectives. *Journal of the Operational Research Society*, 65 (4), 546-556.

Rais, A., Alvelos, F., Carvalho, M.S. (2014). New mixed integer-programming model for the pickup-and-delivery problem with transshipment. *European Journal of Operational Research*, 235 (3), 530-539.

Raith, A., Wang, J.Y.T., Ehrgott, M., Mitchell, S.A. (2013). Solving multi-objective traffic assignment. *Annals of Operations Research*. In Press.

Ramanathan, U., Gunasekaran, A. (2014). Supply chain collaboration: Impact of success in long-term partnerships. *International Journal of Production Economics*, 147 (B), 252-259.

Ramos, T.R.P., Gomes, M.I., Barbosa-Póvoa, A.P. (2014). Planning a sustainable reverse logistics system: Balancing costs with environmental and social concerns. *Omega*. In Press.

Rancourt, M.-E., Paquette, J. (2014). Multicriteria optimization of a long-haul routing and scheduling problem. *Journal of Multi-Criteria Decision Analysis*. In Press.

Razmi, J., Zahedi-Anaraki, A., Zakerinia, M. (2013). A bi-objective stochastic optimization model for reliable warehouse network redesign. *Mathematical and Computer Modelling*, 58 (11-12), 1804-1813.

Redondo, J.L., Fernández, J., Domingo Álvarez Hervás, J., Gila Arrondo, A., Ortigosa, P.M. (2014). Approximating the Pareto-front of a planar bi-objective competitive facility location and design problem. *Computers and Operations Research*. In Press.

Reményi, C., Staudacher, S. (2014). Systematic simulation based approach for the identification and implementation of a scheduling rule in the aircraft engine maintenance. *International Journal of Production Economics*, 147 (A), 94-107.

Ringle, C.M., Sarstedt, M., Schlittgen, R. (2014). Genetic algorithm segmentation in partial least squares structural equation modeling. *OR Spectrum*, 36 (1), 251-276.

Rivera-Gómez, H., Gharbi, A., Kenné, J.P. (2014). Joint production and major maintenance planning policy of a manufacturing system with deteriorating quality. *International Journal of Production Economics*, 146 (2), 575-587.

Robenek, T., Umang, N., Bierlaire, M., Ropke, S. (2014). A branch-and-price algorithm to solve the integrated berth allocation and yard assignment problem in bulk ports. *European Journal of Operational Research*, 235 (2), 399-411.

Roy, B., Figueira, J.R., Almeida-Dias, J. (2014). Discriminating thresholds as a tool to cope with imperfect knowledge in multiple criteria decision aiding: Theoretical results and practical issues. *Omega*, 43, 9-20.

Rudloff, B., Street, A., Valladão, D.M. (2014). Time consistency and risk averse dynamic decision models:

Definition, interpretation and practical consequences. *European Journal of Operational Research*, 234 (3), 743-750.

Ruiz-Benítez, R., Ketzenberg, M., van der Laan, E.A. (2014). Managing consumer returns in high clockspeed industries. *Omega*, 43, 54-64.

Rustogi, K., Strusevich, V.A. (2013). Parallel machine scheduling: Impact Of adding extra machines. *Operations Research*, 61 (5), 1243-1257.

Saaty, T.L. (2013). The modern science of multicriteria decision making and its practical applications: The AHP/ANP approach. *Operations Research*, 61 (5), 1101-1118.

Sabar, N.R., Ayob, M., Kendall, G., Qu, R. (2013). Grammatical evolution hyper-heuristic for combinatorial optimization problems. *IEEE Transaction on Evolutionary Computation*, 17 (6), 840-861.

Sajadieh, M.S., Thorstenson, A. (2014). Comparing sourcing strategies in two-echelon supply chains. *Computers and Operations Research*, 45, 108-115.

Sakulsom, N., Tharmmaphornphilas, W. (2014). Scheduling a music rehearsal problem with unequal music piece length. *Computers & Industrial Engineering*, 70, 20-30.

Salazar-González, J.-J. (2014). Approaches to solve the fleet-assignment, aircraft-routing, crew-pairing and crew-rostering problems of a regional carrier. *Omega*, 43, 71-82.

Sang, X., Liu, X. (2014). An analytic approach to obtain the least square deviation OWA operator weights. *Fuzzy Sets and Systems*, 240, 103-116.

Sarin, R.K. (2013). Median aggregation, scoring rules, expert forecasts, choices with binary attributes, portfolio with dependent projects, and information security. *Decision Analysis*, 10 (4), 277-278.

Sasaki, M., Campbell, J.F., Krishnamoorthy, M., Ernst, A.T. (2014). A Stackelberg hub arc location model for a competitive environment. *Computers and Operations Research*, 47, 27-41.

Sawik, T. (2014). Joint supplier selection and scheduling of customer orders under disruption risks: Single vs. dual sourcing. *Omega*, 43, 83-95.

Sazvar, Z., Mirzapour Al-E-Hashem, S.M.J., Baboli, A., Akbari Jokar, M.R. (2014). A bi-objective stochastic programming model for a centralized green supply chain with deteriorating products. *International Journal of Production Economics*, 150, 140-154.

Schrödl, H., Turowski, K. (2014). Risk management in hybrid value creation. *Decision Support Systems*, 58, 21-30.

Schulz, T., Voigt, G. (2014). A flexibly structured lot sizing heuristic for a static remanufacturing system. *Omega*, 44, 21-31.

Scott, J.A., Ho, W., Dey, P.K. (2013). Strategic sourcing in the UK bioenergy industry. *International Journal of Production Economics*, 146 (2), 478-490.

Serra, T., Chambers, R.G., Oude Lansink, A. (2014). Measuring technical and environmental efficiency in a state-contingent technology. *European Journal of Operational Research*, 236 (2), 706-717.

Sevastyanov, S.V., Chemisova, D.A., Chernykh, I.D. (2014). On some properties of optimal schedules in the job shop problem with preemption and an arbitrary regular criterion. *Annals of Operations Research*, 213 (1), 253-270.

Shabtay, D., Arviv, K., Stern, H., Edan, Y. (2014). A combined robot selection and scheduling problem for flow-shops with no-wait restrictions. *Omega*, 43, 96-107.

Shaik, M.N., Abdul-Kader, W. (2014). Comprehensive performance measurement and causal-effect decision making model for reverse logistics enterprise. *Computers & Industrial Engineering*, 68, 87-103.

Sherali, H.D., Bae, K.-H., Haouari, M. (2013). A benders decomposition approach for an integrated airline schedule design and fleet assignment problem with flight retiming, schedule balance, and demand recapture. *Annals of Operations Research*, 210 (1), 213-244.

Sherali, H.D., Lunday, B.J. (2013). On generating maximal nondominated Benders cuts. *Annals of Operations Research*, 210 (1), 57-72.

Sheu, J.-B., Gao, X.-Q. (2014). Alliance or no alliance - Bargaining power in competing reverse supply chains. *European Journal of Operational Research*, 233 (2), 313-325.

Sheu, S.-H., Liu, T.-H., Zhang, Z.-G., Chang, T.-M. (2014). Optimal number of repairs before replacement for a two-unit system subject to non-homogeneous pure birth process. *Computers & Industrial Engineering*, 69, 71-76.

Shi, J.J., Yue, X., Zhao, Y. (2014). Operations sequencing for a multi-stage production inventory system. *Naval Research Logistics*, 61 (2), 144-154.

Shi, W., Shang, J., Liu, Z., Zuo, X. (2014). Optimal design of the auto parts supply chain for JIT operations: Sequential bifurcation factor screening and multi-response

surface methodology. *European Journal of Operational Research*, 236 (2), 664-676.

Shim, V.A., Tan, K.C., Cheong, C.Y. (2013). An energy-based sampling technique for multi-objective restricted boltzmann machine. *IEEE Transaction on Evolutionary Computation*, 17 (6), 767-785.

Shokouhi, A.H., Shahriari, H., Agrell, P.J., Hatami-Marbini, A. (2014). Consistent and robust ranking in imprecise data envelopment analysis under perturbations of random subsets of data. *OR Spectrum*, 36 (1), 133-160.

Silbermayr, L., Minner, S. (2014). A multiple sourcing inventory model under disruption risk. *International Journal of Production Economics*, 149, 37-46.

Silva, M.M., Costa, A.P.C.S., De Gusmão, A.P.H. (2014). Continuous cooperation: A proposal using a fuzzy multicriteria sorting method. *International Journal of Production Economics*, 151, 67-75.

Simon, J., Kirkwood, C.W., Keller, L.R. (2014). Decision analysis with geographically varying outcomes: Preference models and illustrative applications. *Operations Research*, 62 (1), 182-194.

Sinha, A., Korhonen, P., Wallenius, J., Deb, K. (2014). An interactive evolutionary multi-objective optimization algorithm with a limited number of decision maker calls. *European Journal of Operational Research*, 233 (3), 674-688.

Siraj, S., Mikhailov, L., Keane, J.A. (2013). PriEsT: An interactive decision support tool to estimate priorities from pairwise comparison judgments. *International Transactions in Operational Research*. In Press.

Sitarz, S. (2013). Compromise programming with Techebycheff norm for discrete stochastic orders. *Annals of Operations Research*, 211 (1), 433-446.

Smimou, K. (2014). International portfolio choice and political instability risk: A multi-objective approach. *European Journal of Operational Research*, 234 (2), 546-560.

Sodhi, M.S., Tang, C.S. (2014). Guiding the next generation of doctoral students in operations management. *International Journal of Production Economics*, 150, 28-36.

Soleimani, H., Seyyed-Esfahani, M., Shirazi, M.A. (2013). A new multi-criteria scenario-based solution approach for stochastic forward/reverse supply chain network design. *Annals of Operations Research*. In Press.

Someya, H. (2013). Striking a mean-and parent-centric balance in real-valued crossover operators. *IEEE*

Transaction on Evolutionary Computation, 17 (6), 737-754.

Soylu, B., Akyol, B. (2014). Multi-criteria inventory classification with reference items. *Computers & Industrial Engineering*, 69, 12-20.

Soysal, M., Bloemhof-Ruwaard, J.M., van der Vorst, J.G.A.J. (2014). Modelling food logistics networks with emission considerations: The case of an international beef supply chain. *International Journal of Production Economics*. In Press.

Stanojević, B., Stanojević, M. (2014). Comment on "Fuzzy mathematical programming for multi objective linear fractional programming problem". *Fuzzy Sets and Systems*. In Press.

Sternatz, J. (2014). Enhanced multi-Hoffmann heuristic for efficiently solving real-world assembly line balancing problems in automotive industry. *European Journal of Operational Research*, 235 (3), 740-754.

Stiglmayr, M., Figueira, J.R., Klamroth, K. (2013). On the multicriteria allocation problem. *Annals of Operations Research*. In Press.

Stolyar, A.L. (2013). An infinite server system with general packing constraints. *Operations Research*, 61 (5), 1200-1217.

Su, Y., Geunes, J. (2013). Multi-period price promotions in a single-supplier, multi-retailer supply chain under asymmetric demand information. *Annals of Operations Research*, 211 (1), 447-472.

Sudtachat, K., Mayorga, M.E., Mclay, L.A. (2013). Recommendations for dispatching emergency vehicles under multitiered response via simulation. *International Transactions in Operational Research*. In Press.

Sun, H., Fang, Y., Hsieh, J.J.P.-A. (2014). Consuming information systems: An economic model of user satisfaction. *Decision Support Systems*, 57, 188-199.

Sun, L., DePuy, G.W., Evans, G.W. (2014). Multi-objective optimization models for patient allocation during a pandemic influenza outbreak. *Computers and Operations Research*. In Press.

Sun, M., Zhu, F. (2013). Ad revenue and content commercialization: Evidence from blogs. *Management Science*, 59 (10), 2314-2331.

Suyabatmaz, A.Ç., Altekin, F.T., Şahin, G. (2014). Hybrid simulation-analytical modeling approaches for the reverse logistics network design of a third-party logistics provider. *Computers & Industrial Engineering*, 70, 74-89.

- Szapiro, T., Szufel, P. (2013). Simulated Negotiation Outcomes Through Recommendation Crowding. *Group Decision and Negotiation*. In Press.
- Tai, A.H., Ching, W.-K. (2014). Optimal inventory policy for a Markovian two-echelon system with returns and lateral transshipment. *International Journal of Production Economics*, 151, 48-55.
- Taleizadeh, A.A., Cárdenas-Barrón, L.E., Mohammadi, B. (2014). A deterministic multi product single machine EPQ model with backordering, scraped products, rework and interruption in manufacturing process. *International Journal of Production Economics*, 150, 9-27.
- Tam, B., Ryan, D., Ehrgott, M. (2014). Multi-objective approaches to the unit crewing problem in airline crew scheduling. *Journal of Multi-Criteria Decision Analysis*. In Press.
- Tang, L., Jiang, W., Saharidis, G.K.D. (2013). An improved Benders decomposition algorithm for the logistics facility location problem with capacity expansions. *Annals of Operations Research*, 210 (1), 165-190.
- Theißen, S., Spinler, S. (2014). Strategic analysis of manufacturer-supplier partnerships: An ANP model for collaborative CO2 reduction management. *European Journal of Operational Research*, 233 (2), 383-397.
- Tirkel, I., Rabinowitz, G. (2014). Modeling cost benefit analysis of inspection in a production line. *International Journal of Production Economics*, 147 (A), 38-45.
- Tjader, Y., May, J.H., Shang, J., Vargas, L.G., Gao, N. (2014). Firm-level outsourcing decision making: A balanced scorecard-based analytic network process model. *International Journal of Production Economics*, 147 (C), 614-623.
- Tjosvold, D., Chen, N.Y., Huang, X., Xu, D. (2014). Developing Cooperative Teams to Support Individual Performance and Well-Being in a Call Center in China. *Group Decision and Negotiation*, 23 (2), 325-348.
- Toso, E.A.V., Alem, D. (2014). Effective location models for sorting recyclables in public management. *European Journal of Operational Research*, 234 (3), 839-860.
- Trautmann, H., Wagner, T., Biermann, D., Weihs, C. (2013). Indicator-based selection in evolutionary multiobjective optimization algorithms based on the desirability index. *Journal of Multi-Criteria Decision Analysis*, 20 (5-6), 319-337.
- Tsai, H.-T., Pai, P. (2014). Why do newcomers participate in virtual communities? An integration of self-determination and relationship management theories. *Decision Support Systems*, 57, 178-187.
- Tsai, T.-N. (2014). Selection of the optimal configuration for a flexible surface mount assembly system based on the interrelationships among the flexibility elements. *Computers & Industrial Engineering*, 67, 146-159.
- Turner, J.P., Rodriguez, H.E., DaRosa, D.A., Daskin, M.S., Hayman, A., Mehrotra, S. (2013). Northwestern University Feinberg School of Medicine uses operations research tools to improve surgeon training. *Interfaces*, 43 (4), 341-351.
- Ulrich, T. (2013). Pareto-set analysis: Biobjective clustering in decision and objective spaces. *Journal of Multi-Criteria Decision Analysis*, 20 (5-6), 217-234.
- Utz, S., Wimmer, M., Hirschberger, M., Steuer, R.E. (2014). Tri-criterion inverse portfolio optimization with application to socially responsible mutual funds. *European Journal of Operational Research*, 234 (2), 491-498.
- Validi, S., Bhattacharya, A., Byrne, P.J. (2014). A case analysis of a sustainable food supply chain distribution system-A multi-objective approach. *International Journal of Production Economics*. In Press.
- Verbeeck, C., Sörensen, K., Aghezzaf, E.-H., Vansteenwegen, P. (2014). A fast solution method for the time-dependent orienteering problem. *European Journal of Operational Research*, 236 (2), 419-432.
- Vetschera, R., Filzmoser, M., Mitterhofer, R. (2014). An Analytical Approach to Offer Generation in Concession-Based Negotiation Processes. *Group Decision and Negotiation*, 23 (1), 71-99.
- Vetschera, R., Weitzl, W., Wolfsteiner, E. (2014). Implausible alternatives in eliciting multi-attribute value functions. *European Journal of Operational Research*, 234 (1), 221-230.
- Vidal, T., Crainic, T.G., Gendreau, M., Prins, C. (2014). A unified solution framework for multi-attribute vehicle routing problems. *European Journal of Operational Research*, 234 (3), 658-673.
- Vieira, D.A.G., Lisboa, A.C. (2014). Line search methods with guaranteed asymptotical convergence to an improving local optimum of multimodal functions. *European Journal of Operational Research*, 235 (1), 38-46.
- Vilkumaa, E., Liesiö, J., Salo, A. (2014). Optimal strategies for selecting project portfolios using uncertain value estimates. *European Journal of Operational Research*, 233 (3), 772-783.

- Vilkumaa, E., Salo, A., Liesiö, J. (2014). Multicriteria Portfolio Modeling for the Development of Shared Action Agendas. *Group Decision and Negotiation*, 23 (1), 49-70.
- Villacorta, K.D.V., Oliveira, P.R., Soubeyran, A. (2014). A Trust-Region Method for Unconstrained Multiobjective Problems with Applications in Satisficing Processes. *Journal of Optimization Theory and Applications*, 160 (3), 865-889.
- Vinué, G., León, T., Alemany, S., Ayala, G. (2014). Looking for representative fit models for apparel sizing. *Decision Support Systems*, 57, 22-33.
- Vitorino, M.A. (2014). Understanding the effect of advertising on stock returns and firm value: Theory and evidence from a structural model. *Management Science*, 60 (1), 227-245.
- Waligóra, G. (2014). Discrete-continuous project scheduling with discounted cash inflows and various payment models-a review of recent results. *Annals of Operations Research*, 213 (1), 319-340.
- Wang, G., Jia, N., Ma, S., Qi, H. (2014). A rank-dependent bi-criterion equilibrium model for stochastic transportation environment. *European Journal of Operational Research*, 235 (3), 511-529.
- Wang, H. (2013). Zigzag search for continuous multiobjective optimization. *INFORMS Journal on Computing*, 25 (4), 654-665.
- Wang, J.-Q., Peng, J.-J., Zhang, H.-Y., Liu, T., Chen, X.-H. (2014). An Uncertain Linguistic Multi-criteria Group Decision-Making Method Based on a Cloud Model. *Group Decision and Negotiation*. In Press.
- Wang, J.Q., Wang, D.D., Zhang, H.y., Chen, X.H. (2013). Multi-criteria outranking approach with hesitant fuzzy sets. *OR Spectrum*, In Press.
- Wang, S., Huang, G.H. (2014). An integrated approach for water resources decision making under interactive and compound uncertainties. *Omega*, 44, 32-40.
- Wang, Y., Li, L. (2014). A PSO algorithm for constrained redundancy allocation in multi-state systems with bridge topology. *Computers & Industrial Engineering*, 68, 13-22.
- Wang, Z., Liang, W., Hu, X. (2014). A metaheuristic based on a pool of routes for the vehicle routing problem with multiple trips and time windows. *Journal of the Operational Research Society*, 65 (1), 37-48.
- Wei, Y., Xu, C., Hu, Q. (2013). Transformation of optimization problems in revenue management, queueing system, and supply chain management. *International Journal of Production Economics*, 146 (2), 588-597.
- Wex, F., Schryen, G., Feuerriegel, S., Neumann, D. (2014). Emergency response in natural disaster management: Allocation and scheduling of rescue units. *European Journal of Operational Research*, 235 (3), 697-708.
- Wong, W.K., Guo, Z.X., Leung, S.Y.S. (2014). Intelligent multi-objective decision-making model with RFID technology for production planning. *International Journal of Production Economics*, 147 (C), 647-658.
- Wu, D., Luo, C., Liang, L., Dolgui, A. (2014). Efficiency evaluation model with constraint resource: An application to banking operations. *Journal of the Operational Research Society*, 65 (1), 14-22.
- Wu, J.Z., Zhang, Q., Du, Q., Dong, Z. (2014). Compromise principle based methods of identifying capacities in the framework of multicriteria decision analysis. *Fuzzy Sets and Systems*. In Press.
- Xiong, H., Chen, Y.-J. (2014). Product line design with seller-induced learning. *Management Science*, 60 (3), 784-795.
- Xu, J., Wu, Z., Zhang, Y. (2014). A Consensus Based Method for Multi-criteria Group Decision Making Under Uncertain Linguistic Setting. *Group Decision and Negotiation*, 23 (1), 127-148.
- Xu, Y., Li, K.W., Wang, H. (2014). Incomplete interval fuzzy preference relations and their applications. *Computers & Industrial Engineering*, 67, 93-103.
- Yan, S., Lin, C.-K., Chen, S.-Y. (2014). Logistical support scheduling under stochastic travel times given an emergency repair work schedule. *Computers & Industrial Engineering*, 20-35.
- Yang, D.-L., Lai, C.-J., Yang, S.-J. (2014). Scheduling problems with multiple due windows assignment and controllable processing times on a single machine. *International Journal of Production Economics*, 150, 96-103.
- Yang, F., Song, S., Huang, W., Xia, Q. (2014). SMAA-PO: project portfolio optimization problems based on stochastic multicriteria acceptability analysis. *Annals of Operations Research*. In Press.
- Yang, J.-B., Xu, D.-L. (2014). Interactive minimax optimisation for integrated performance analysis and resource planning. *Computers and Operations Research*, 46, 78-90.
- Yang, N., Liao, X., Huang, W.W. (2014). Decision support for preference elicitation in multi-attribute electronic procurement auctions through an agent-based intermediary. *Decision Support Systems*, 57, 127-138.

- Yang, W.-E. (2014). Semantic dominance analysis for multicriteria decision-making problems with unbalanced linguistic scale. *International Transactions in Operational Research*. In Press.
- Yang, X., Yang, Z. (2014). Synchronization of TS fuzzy complex dynamical networks with time-varying impulsive delays and stochastic effects. *Fuzzy Sets and Systems*, 235, 25-43.
- Yang, Y., Chen, Y., Zhou, Y. (2014). Coordinating inventory control and pricing strategies under batch ordering. *Operations Research*, 62 (1), 25-37.
- Yanikoğlu, I., Den Hertog, D. (2013). Safe approximations of ambiguous chance constraints using historical data. *INFORMS Journal on Computing*, 25 (4), 666-681.
- Yano, H., Sakawa, M. (2014). Interactive fuzzy programming for multiobjective fuzzy random linear programming problems through possibility-based probability maximization. *Operational Research*, 14 (1), 51-69.
- Ye, Z.-S., Tang, L.-C., Xie, M. (2014). Bi-objective burn-in modeling and optimization. *Annals of Operations Research*, 212 (1), 201-214.
- Yen, G.G., He, Z. (2014). Performance metric ensemble for multiobjective evolutionary algorithms. *IEEE Transaction on Evolutionary Computation*, 18 (1), 131-144.
- Yenisey, M.M., Yagmahan, B. (2014). Multi-objective permutation flow shop scheduling problem: Literature review, classification and current trends. *Omega*, 45, 119-135.
- Ying, K.-C., Lin, S.-W. (2014). Efficient wafer sorting scheduling using a hybrid artificial immune system. *Journal of the Operational Research Society*, 65 (2), 169-179.
- Yu, W., Liu, Z. (2014). Vehicle routing problems with regular objective functions on a path. *Naval Research Logistics*, 61 (1), 34-43.
- Yu, Y., Tang, J., Gong, J., Yin, Y., Kaku, I. (2014). Mathematical analysis and solutions for multi-objective line-cell conversion problem. *European Journal of Operational Research*, 236 (2), 774-786.
- Yusuf, Y.Y., Gunasekaran, A., Musa, A., El-Berishy, A.M., Abubakar, T., Ambursa, H.M. (2013). The UK oil and gas supply chains: An empirical analysis of adoption of sustainable measures and performance outcomes. *International Journal of Production Economics*, 146 (2), 501-514.
- Yusuf, Y.Y., Musa, A., Dauda, M., El-Berishy, N., Kovvuri, D., Abubakar, T. (2014). A study of the diffusion of agility and cluster competitiveness in the oil and gas supply chains. *International Journal of Production Economics*, 147 (B), 498-513.
- Zaraket, F.A., Olleik, M., Yassine, A.A. (2014). Skill-based framework for optimal software project selection and resource allocation. *European Journal of Operational Research*, 234 (1), 308-318.
- Zhang, B., Ng, C.T., Cheng, T.C.E. (2014). Multi-period empty container repositioning with stochastic demand and lost sales. *Journal of the Operational Research Society*, 65 (2), 302-319.
- Zhang, R., Chiang, W.-C., Wu, C. (2014). Investigating the impact of operational variables on manufacturing cost by simulation optimization. *International Journal of Production Economics*, 147 (C), 634-646.
- Zhang, S., Tang, G.J., Friswell, M.I., Wagg, D.J. (2014). Multi-objective Optimization of Zero Propellant Spacecraft Attitude Maneuvers. *Journal of Optimization Theory and Applications*. In Press.
- Zhang, W., Reimann, M. (2014). A simple augmented ϵ -constraint method for multi-objective mathematical integer programming problems. *European Journal of Operational Research*, 234 (1), 15-24.
- Zhang, W.-G., Liu, Y.-J. (2014). Credibilitic mean-variance model for multi-period portfolio selection problem with risk control. *OR Spectrum*, 36 (1), 113-132.
- Zhang, Z., Guo, C. (2014). An approach to group decision making with heterogeneous incomplete uncertain preference relations. *Computers & Industrial Engineering*, 71, 27-36.
- Zhang, Z., Wang, C., Tian, D., Li, K. (2014). Induced generalized hesitant fuzzy operators and their application to multiple attribute group decision making. *Computers & Industrial Engineering*, 67, 116-138.
- Zhao, F., Tang, J., Wang, J., Jonrinaldi (2014). An improved particle swarm optimization with decline disturbance index (DDPSO) for multi-objective job-shop scheduling problem. *Computers and Operations Research*, 45, 38-50.
- Zheng, Y.-J., Ling, H.-F., Xue, J.-Y., Chen, S.-Y. (2014). Population classification in fire evacuation: A multiobjective particle swarm optimization approach. *IEEE Transaction on Evolutionary Computation*, 18 (1), 70-81.
- Zhou, H., Shou, Y., Zhai, X., (...), Wood, C., Wu, X. (2014). Supply chain practice and information quality: A supply chain strategy study. *International Journal of Production Economics*, 147 (C), 624-633.

Zhu, B., Xu, Z.S. (2013). Hesitant fuzzy Bonferroni means for multi-criteria decision making. Journal of the Operational Research Society, 64 (12), 1831-1840.

Seminars

SEMINAIRE « MODELISATION DES PREFERENCES ET AIDE MULTICRITERE A LA DECISION »

Responsables : Bernard ROY, Daniel VANDERPOOTEN (le mardi à 14h00 – salles à préciser)

Prochaines réunions

28 janvier 2014 Conférence de Eyke Hüllermeier (Université de Marburg, Allemagne)

Preference-based Racing Algorithms for PAC Rank Elicitation (résumé voir pièce jointe)

18 février 2014 Présentation des travaux de Julien Roland (Université Exceptionnellement Libre de Bruxelles, Belgique) à 15h au lieu de 14h Optimisation inverse multi-objectifs : théorie, algorithmes et applications

(résumé voir pièce jointe)

11 mars 2014 Conférence de Tina Comes (University of Agder, Norway)

Decision Support in Emergency Management: Confronting Complexity and Uncertainty

(résumé voir pièce jointe)

8 avril 2014 Conférence de Vincent Mousseau 1, Marc Pirlot 2 et Olivier Sobrie 1;2 (1 Ecole Centrale de Paris, 2 Université de Mons)

Comment apprendre un modèle MR-Sort à partir d'un grand ensemble d'exemple d'affectation

(résumé voir pièce jointe)

20 mai 2014 Conférence de Jean-Luc Marichal (Université de Luxembourg)

Fonctions d'agrégation associatives et préassociatives

(résumé voir pièce jointe)

10 juin 2014 Conférence de Margaret Wiecek (Clemson University, South Carolina)

Robust Multiobjective Optimization

(résumé voir pièce jointe)

Persons and Facts

Subhush Narula
Virginia Common Wealth University
(1944-2013)

It's an honour for me to speak about a great man who contributed a lot in Multicriteria Decision Making Theory. Subhush was also a friendly person. He has many friends all over the world and has always supported them. He is humble and when someone compliments him about his wisdom and great sense of judgment, he smiles and says "I'm your mirror". Rest in peace my dear friend!!

Hella Ben Brahim Neji

Announcement:

The "Useful links" section of the group's homepage

(www.cs.put.poznan.pl/ewgmcda)

is being enlarged. Contributions of URL links to societies, research groups and other links of interest are welcome.

A membership directory of the European Working Group on "Multiple Criteria Decision Aiding" is available at the same site. If you would like to be listed in this directory please send us your data (see examples already in the directory).

Contact: José Rui Figueira (figueira@ist.utl.pt)

Web site for the EURO Working Group "Multicriteria Aid for Decisions"

A World Wide Web site for the EURO Working Group on "Multicriteria Aid for Decisions" is already available at the URL:

<http://www.cs.put.poznan.pl/ewgmcda/>

Web site Editor: Milosz Kadzinski
(Milosz.Kadzinski@cs.put.poznan.pl)

This WWW site is aimed not just at making available the most relevant information contained in the Newsletter sections, but it also intends to become an online discussion forum, where other information and opinion articles could appear in order to create a more lively atmosphere within the group.

Groupe de Travail Européen "Aide Multicritère à la Décision" / European Working Group "Multiple Criteria Decision Aiding"

Board of Coordinators of the EURO Working Group:

Roman Slowinski
José Rui Figueira
Salvatore Greco
Bernard Roy (Honorary Chairman)

Newsletter editor:

José Rui Figueira

Permanent Collaborators:

*Silvia Angilella, Maria João Alves, Carlos Henggeler Antunes,
Juscelino Almeida-Dias, Salvatore Corrente*

José Rui Figueira
Instituto Superior Tecnico
Departamento de Engenharia e Gestao
Campus da Alameda
Av. Rovisco Pais
1049-001 Lisboa, Portugal
E-mail: figueira@ist.utl.pt

URL:

<http://www.cs.put.poznan.pl/ewgmcda>

*This newsletter is published twice a year by the "EWG on MCDA", in November/December and April/May, with financial support of the Association of European Operational Research
Contributions should be sent to:
José Rui Figueira (figueira@ist.utl.pt)*